

escea.

OUTDOOR GAS FIREPLACE  
USER GUIDE  
North America

630113



EF5000

[www.escea.net](http://www.escea.net)

Any service work carried out on this appliance must only be done by a recognised escea technician or authorized personnel.

The data plate for this appliance, containing technical information and specifications, can be found to the right of the control tray, near the base of the fire. To access this, the fascia must be removed.

DO NOT PLACE ARTICLES ON OR AGAINST THIS APPLIANCE.

DO NOT USE OR STORE FLAMMABLE MATERIALS NEAR THIS APPLIANCE.

DO NOT SPRAY AEROSOLS IN THE VICINITY OF THIS APPLIANCE WHILST IT IS IN OPERATION.

IT IS NOT RECOMMENDED TO OPERATE THE FIRE WITH THE FASCIA PANELS REMOVED.

THIS APPLIANCE IS NOT INTENDED FOR USE BY YOUNG CHILDREN OR INFIRM PERSONS UNLESS THEY HAVE BEEN ADEQUATELY SUPERVISED BY A RESPONSIBLE PERSON TO ENSURE THAT THEY CAN USE THE APPLIANCE SAFELY.

YOUNG CHILDREN SHOULD BE SUPERVISED TO ENSURE THAT THEY DO NOT PLAY WITH THE APPLIANCE.

THE APPLIANCE MUST BE INSPECTED BEFORE USE AND AT LEAST ANNUALLY BY AN AUTHORISED TECHNICIAN.

THIS APPLIANCE MUST BE INSTALLED IN ACCORDANCE WITH THE MANUFACTURERS WRITTEN INSTRUCTIONS.

FOR OUTDOOR USE ONLY

escea.

31 Devon St, PO Box 5277

Dunedin, New Zealand

E-mail: [info@escea.net](mailto:info@escea.net)

Web: [www.escea.net](http://www.escea.net)

Phone: 64 3 479 0302 Fax: 64 3 479 0301

escea.

## Contents

Basic Operation	1
Removing the Fascia	4
Replacing Batteries	5
Cleaning and Maintenance	6
Warranty Information	7

## Basic Operation

The EF5000 is operated by the touch control located on the Right hand side outer edge of the fascia. The basic operations possible from the touch control are ON/OFF and manual adjustment of the flame height. **Before operating the fire, switch the Battery Isolating Switch on.**

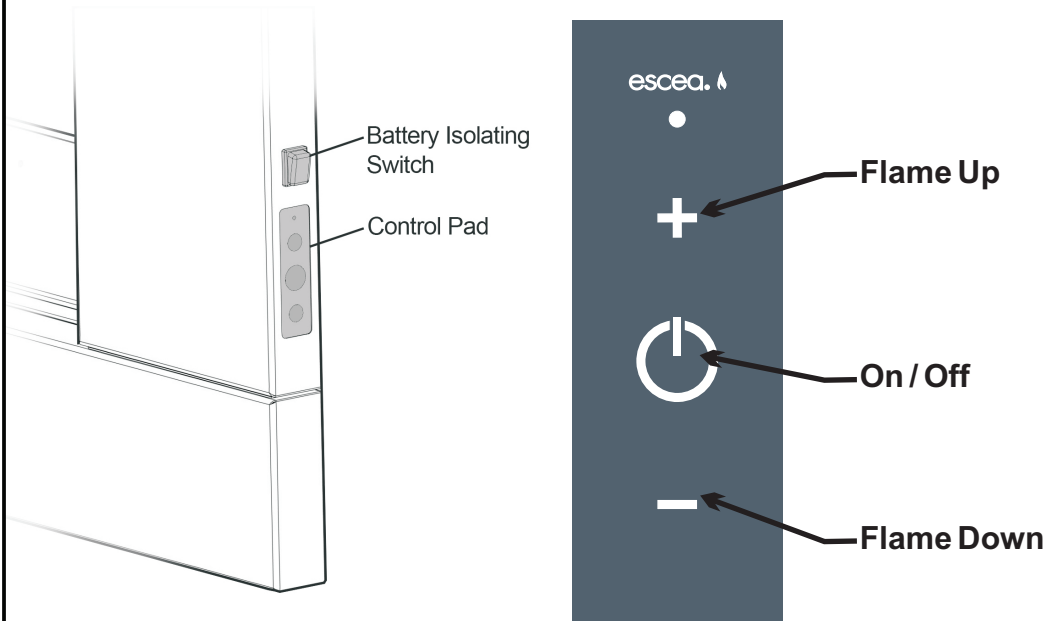

### **Ignition:**

To turn on the fire push the ON/OFF button on the touch control. The pilot will start sparking and gas will start flowing to the pilot which should light and be visible in a few seconds.

The ignition process takes a duration of 12 seconds. No other button should be pressed during those 12 seconds.

In the event of the pilot not igniting after 12 seconds press the ON/OFF button. This will turn the valve off completely, then restart the ignition process.

## Basic Operation

### **Turning on the main burners:**

Once the pilot flame has been running for 6 seconds press the FLAME UP button to release gas to the two main burners

The EF5000 has 4 flame positions: PILOT flame only, LOW burner flame, MEDIUM burner flame and HIGH burner flame.

### **Adjusting the flame height:**

While the fire is on, push the FLAME UP button or the FLAME DOWN button to increase or decrease the flame height.

If the FLAME UP button is pushed while the fire is on HIGH burner flame position, nothing will happen. Similarly if the FLAME DOWN button is pushed while fire is in the PILOT flame position, nothing will happen.

### **Turning off the fire:**

To turn the fire off, you must push the ON/OFF button. This will shut down the gas flow to the pilot flame and both burners.

It is recommended that if you will not be using your fire for long periods of time to switch it off at the isolation switch. This will also extend the battery life.

### **Gas supply interruption:**

In the event that the gas supply is interrupted during the operation of this appliance, and then is re-established immediately, you must turn off the battery isolating switch and not attempt to relight the appliance for at least 5 minutes.

# Basic Operation

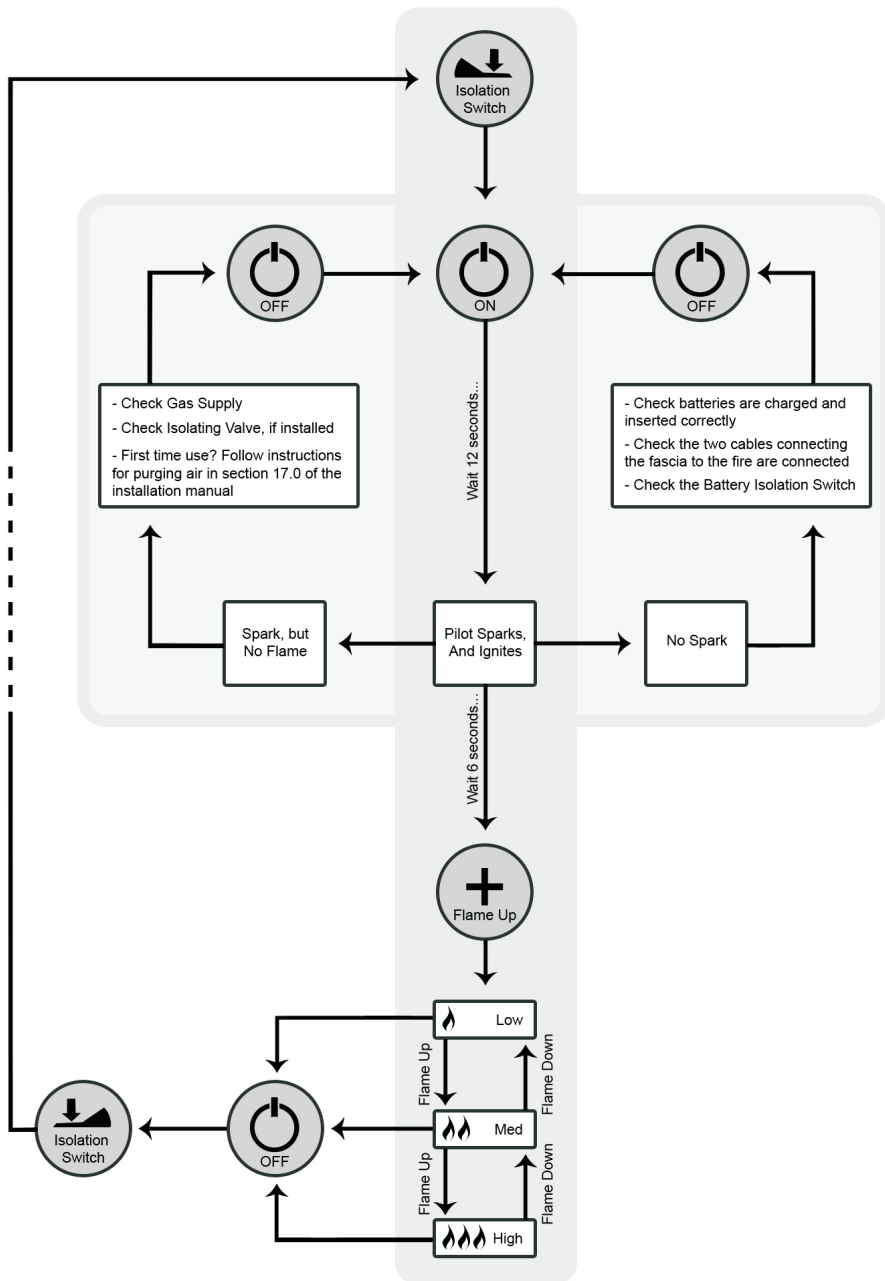

## Removing the Fascia

The EF5000 Stainless Steel fascia is attached to the fire by four 'hooks' on the corners of the fascia. If you need to remove the fascia, first give the fascia a brief lift upwards as shown.

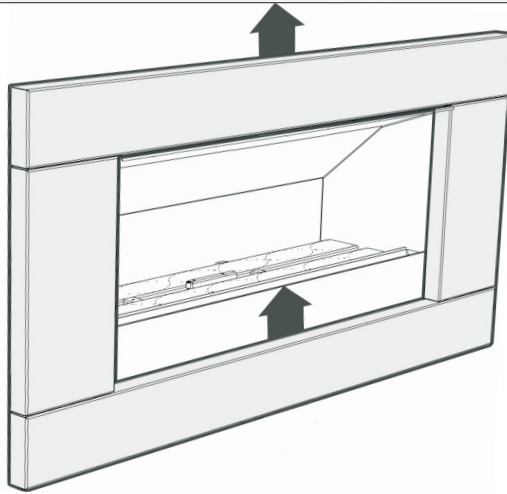

Now pull the fascia towards you, and rest the Fascia on the brackets half way down the firebox, or on the ground while you unplug the two cords connecting the fascia to the fire.

Brackets to rest the top fascia hooks on while disconnecting the control cords.

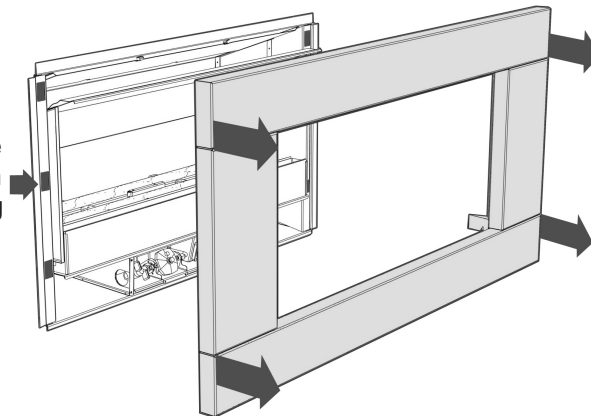

Reverse these steps to re-fit the Fascia, ensuring the two connections are correctly plugged in by testing the fire.

## Replacing Batteries

The EF5000 uses 3x D sized batteries, To access the battery pack you will need to remove the fascia (as described on previous page).

When the fascia has been removed, you will find the battery pack located in the lower middle of the fire, situated inside the control box.

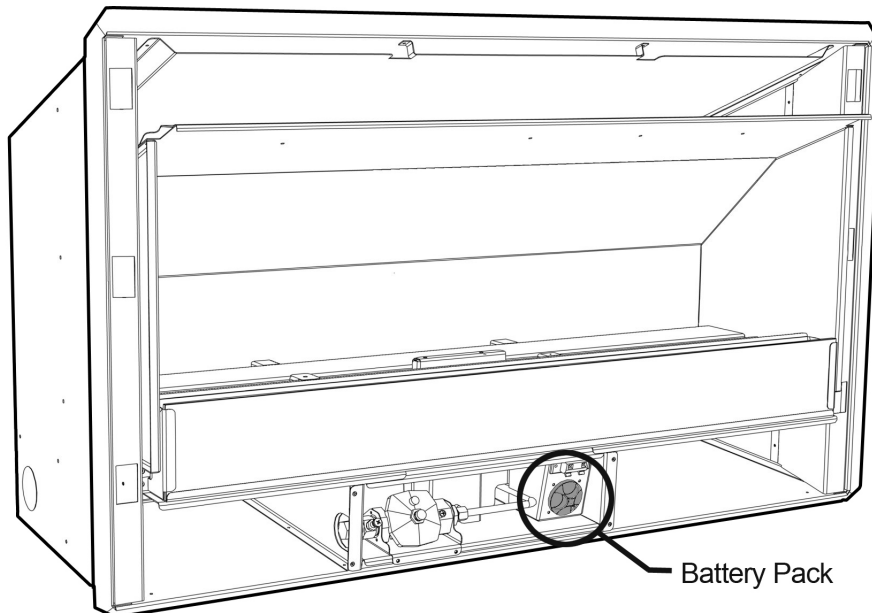

Remove the cap of the battery pack, turn it anti-clockwise until it stops, then pull. The batteries inside should slide out.

Once the new batteries have been placed inside, (with the dimple facing outwards) replace the cap and turn it clockwise until it stops to seal it.

## Cleaning your EF5000

Do not perform any cleaning unless the fireplace has been turned off and allowed to cool for at least 30 minutes. Also the gas supply valve to the fireplace should be turned off while cleaning is in progress

To clean the glass and stones in the front stone tray simply reverse the steps in section 14.0 of the Installation Manual.

The glass can be cleaned using standard window cleaner. The quartz stones can be washed using soapy water

If the stainless steel fascia or weather cover require cleaning the following products are recommended; 3M Stainless steel cleaner, methylated spirits. Note: Fascia must be removed from the appliance before using flammable cleaning products

Cleaning of the ceramic stones and burners can be carried out using a brush and a dry cloth

**LIMITED WARRANTY:**

Provided that the Product is installed as per ESCEA's Installation Manual and the step by step warranty procedure has been followed as per instructions issued by ESCEA, (documented in the Dealer Manual), and the product is operated and maintained in accordance with ESCEA operating and maintenance instructions, then for the first period of twelve (12) months from the date of purchase ESCEA will pay to the dealer who sold the appliance, a pre-determined sum to repair or replace any part of the Product that is deemed by ESCEA to be faulty.

For the second period of twelve (12) months from the date of purchase ESCEA will supply replacement parts only, without charge.

Parts and Labor for the first twelve (12) months:

- a) ESCEA, at its sole discretion and through its dealer, may modify, adjust, repair, or replace the faulty products. The warranty period on parts and labor shall be for twelve (12) months from the date of purchase.
- b) Pre-determined labor costs will only be reimbursed when ESCEA specified procedure has been followed, and ESCEA has authorized service work before it was carried out.

Parts Only for the second twelve (12) months:

- a) ESCEA, at its sole discretion, will provide replacement parts to its dealer for the benefit of an end user. Faulty parts MUST be returned to ESCEA. The parts only warranty period shall be for twelve (12) months and will commence twelve (12) months after the acceptance date of the Products by the ESCEA retailer.

General Terms and Exclusions:

1. All repairs made within the Limited Warranty period shall be covered by this Limited Warranty for a period of three (3) months from the date of completion of the repair, or for the remainder of the overall Limited Warranty period, whichever is the longer.
2. If the buyer or any other party modifies any part of the product within the Limited Warranty period without the prior written consent of ESCEA then the Limited Warranty shall be void. ESCEA may, at its sole discretion, decide that the Limited Warranty is void in relation to any part of the product, which has been modified.
3. ESCEA must be notified of all claims under this Limited Warranty as soon as possible, but in any event not later than two (2) weeks of the claimant becoming aware of the circumstance giving rise to the claims.
4. No ESCEA Distributor, retailer, employee or other third party is authorized to make any modification, extension, or addition to this Limited Warranty, whether verbal or written.
5. ESCEA reserves the right to discontinue products or make substitutions, in such event, the buyer may receive a substitute product or a cash refund at ESCEA'S sole discretion, if a replacement for the product covered by this Limited Warranty is no longer available.
6. ESCEA is not responsible for damage arising from failure to follow instructions for the product's installation, maintenance and permitted and proper use. The Limited Warranty does not cover damage caused by use with non-ESCEA products or damage caused by accident, abuse, misuse, weather, fire, flood, earthquake or other external causes. Products where an ESCEA serial number has been removed or defaced or damage caused by incorrect fuel type or flueing are also not covered. Cosmetic damage, including but not limited to paint blemishes, scratches, non structural surface rust, water damage and normal fair wear and tear are not covered as well. Gas Fireplaces require annual service, problems caused by not having this service done such as (but not limited to) dust and debris build up, flat batteries, insects present in burners, incorrect gas pressure and worn thermocouples are also not covered under this warrantee.

**LIMITATION OF REMEDIES:****TO THE EXTENT PERMITTED BY LAW:**

This limited warranty, and the remedies set forth above, are exclusive and in lieu of all other warranties, remedies and conditions, whether verbal or written, statutory, express or implied.

Escea specifically disclaims any and all statutory or implied warranties and conditions, including, without limitation, warranties of merchantability, fitness for a particular purpose and warranties against latent defects.

Except as provided herein, Escea is not responsible for direct, special, incidental or consequential loss or damages resulting from any breach of warranty or condition, or under any other legal theory, including but not limited to the loss of any of the following: use; revenue; actual or anticipated profits (including loss of profits on contracts); use of money; anticipated savings; business; opportunity; goodwill; reputation; any or indirect or consequential loss or damage howsoever caused including the replacement or equipment and property.

Some states in Canada and in some States in the United States do not allow the exclusion of incidental or consequential damages, so the above limitation may not apply to buyer.

escea.