

## Installation Manual

EF5000 - US

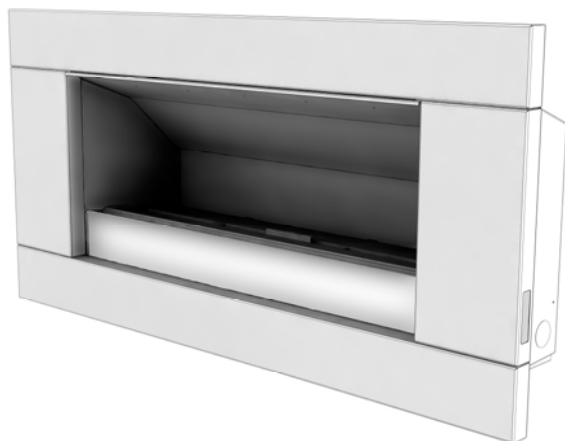

**WARNING:** If the information in this manual is not followed exactly, a fire or explosion may result causing property damage, personal injury or loss of life.

- Do not store or use gasoline or other flammable vapors and liquids in the vicinity of this or any other gas appliance.
- **WHAT TO DO IF YOU SMELL GAS:**
  - Do not try to light any appliance.
  - Do not touch any electrical switch; do not use any phone in your building.
  - Immediately call your gas supplier from a neighbour's phone. Follow the gas suppliers instructions.
  - If you cannot reach your gas supplier, call the fire department.
- Installation and service must be performed by a qualified installer, service agency or gas supplier.
- Instructions must be left with the consumer and the consumer to retain them for future reference

**WARNING:** Improper installation, adjustment, alteration, service or maintenance can cause injury or property damage. Read the installation, operating and maintenance instructions thoroughly before installing or servicing this equipment.

**WARNING:** For Outdoor Use Only.

## Important:

The appliance shall be installed in accordance with;

- Local gas fitting and building codes, or in the absence of local codes, with the *National Fuel Gas Code, ANSI Z223.1*
- The appliance, when installed, must be electrically grounded in accordance with local codes or, in the absence of local codes, with the *National Electrical Code, ANSI/NFPA 70*. (If applicable)

This appliance must only be installed by an authorized person.

## Warning:

The area surrounding the appliance must be clear and free from combustible materials, gasoline and other flammable vapors and liquids.

This appliance must not be installed or used indoors.

Children and adults should be alerted to the hazards of high surface temperatures and should stay away to avoid burns or clothing ignition.

Young children should be carefully supervised when they are in the area of the appliance.

Clothing or other flammable materials should not be hung from the appliance, or placed on or near the appliance.

Any guard or other protective device removed for servicing the appliance must be replaced prior to operating the appliance.

Installation and repair should be done by a qualified service person. The appliance should be inspected before use and at least annually by a qualified service person. More frequent cleaning may be required as necessary. It is imperative that control compartment, burners and circulating air passageways of the appliance be kept clean.

Do not use this appliance if any part has been under water. Immediately call a qualified service technician to inspect the appliance and to replace any part of the control system and any gas control which has been under water.

Under no circumstances should you touch the coils or metalwork during operation.

## Contact:

For further information or advice please contact:

Ph. USA: 1 866 615 3096

Email: [techsupport@escea.net](mailto:techsupport@escea.net)

Manufactured by: Escea Ltd, PO Box 5277 Dunedin NZ, Ph: +64 3 478 8220, email: [info@escea.net](mailto:info@escea.net)

Contents:	Page:
Product description_____	1.0
Power supply _____	2.0
Creating the cavity_____	3.0
Cavity Dimensions_____	4.0
Wall cladding around the fire_____	5.0
Minimum install height off the ground_____	6.0
Corner Installations_____	7.0
Laying gas pipe_____	8.0
Fixing the fire into the cavity_____	9.0
Connecting gas pipe_____	10.0
Connecting the power supply and touch panel_____	11.0
Testing of touch panel and spark ignition_____	12.0
Checking operating pressure_____	13.0
Assembly of stone cartridge_____	14.0
Fitting the fascia_____	15.0
Placement of ceramic pebbles_____	16.0
Operating Instructions_____	17.0
Maintenance and cleaning_____	18.0
Replacement Parts_____	19.0

## 1.0 Product Description:

The escea EF5000 flame effect gas fire is designed for outdoor use only. This appliance requires no flue and must be permanently installed into a cavity. It may be installed into a timber cavity.

The fire is controlled by the user, from a touch panel that is situated on the lower right hand side of the stainless steel fascia, or if the 'wall mount' option is chosen, the remote will be situated on the wall near the fire, connected by a cord.

The Data Plate, containing all technical information such as manufacture date, serial number, gas type, jet size, etc, can be found in the lower right hand side of the fire, below the firebox. To access this the fascia must be removed.

## 1.1 Product dimensions: (in)

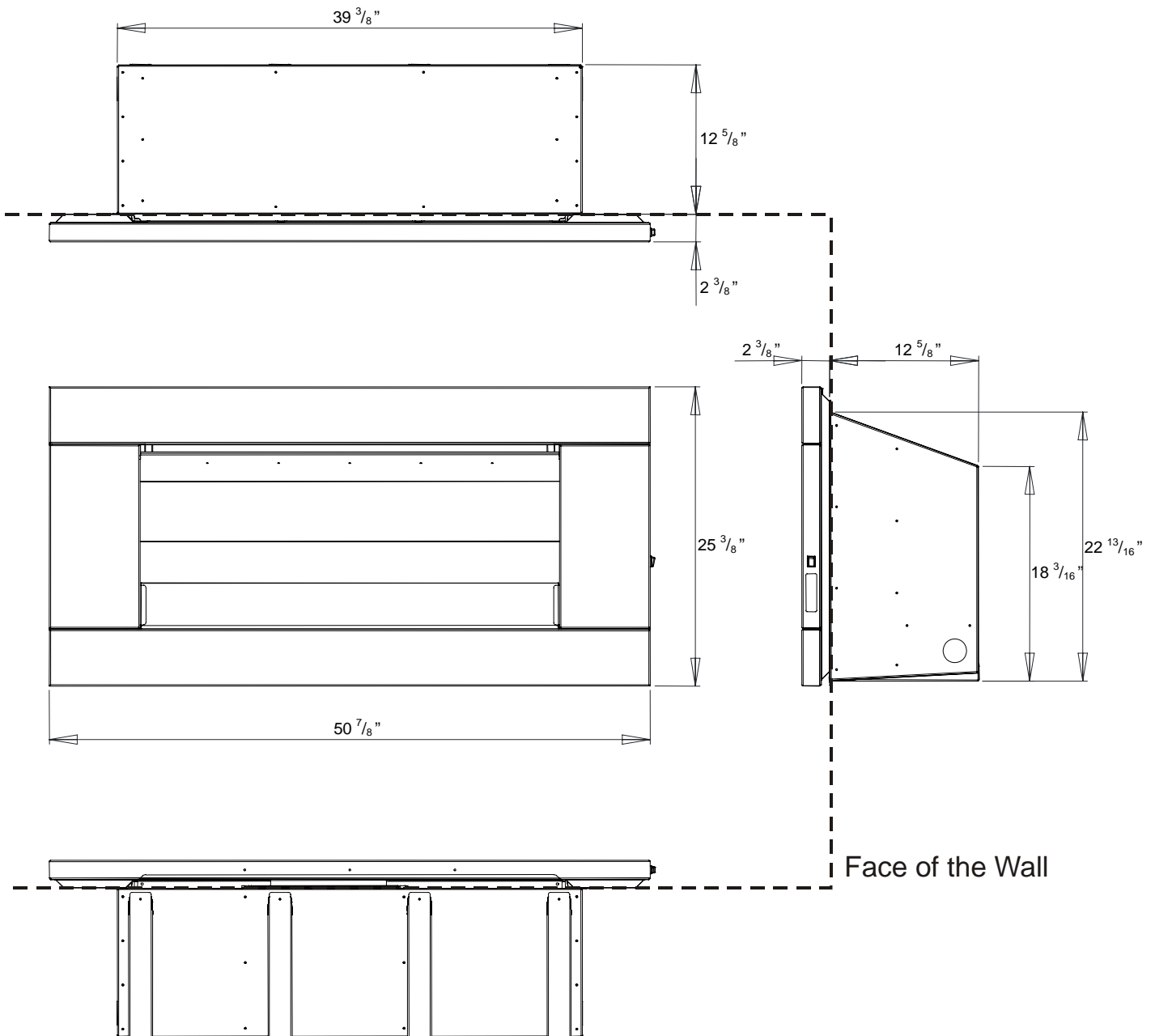

## 2.0 Power Supply:

This appliance requires 3 'D' sized cell batteries for operation, which are located in a battery pack inside the control tray behind the fascia, at the base of the fire. Alternatively, you can use the External Power Supply, described in section 2.2 of this manual.

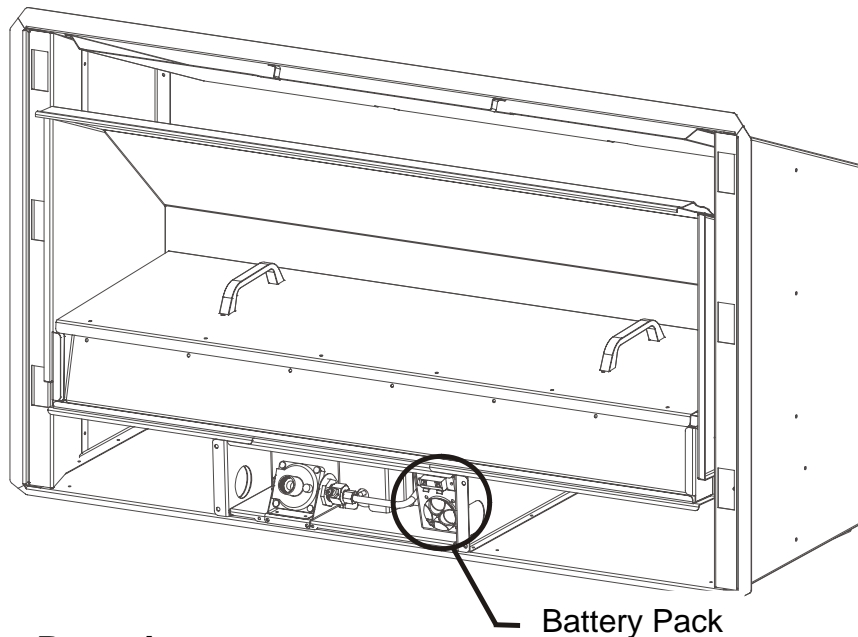

### 2.1 Replacing Batteries:

To replace the batteries, remove the fascia to gain access to the battery pack pictured above. To remove the cap of the battery pack turn it anti-clockwise until it stops, then pull. The batteries inside should slide out. Ensure you replace the batteries in the correct way, dimple facing out.

Once the new batteries have been placed inside, replace the cap and turn it clockwise until it stops, to seal it.

### 2.2 Alternate Power Source: (Optional)

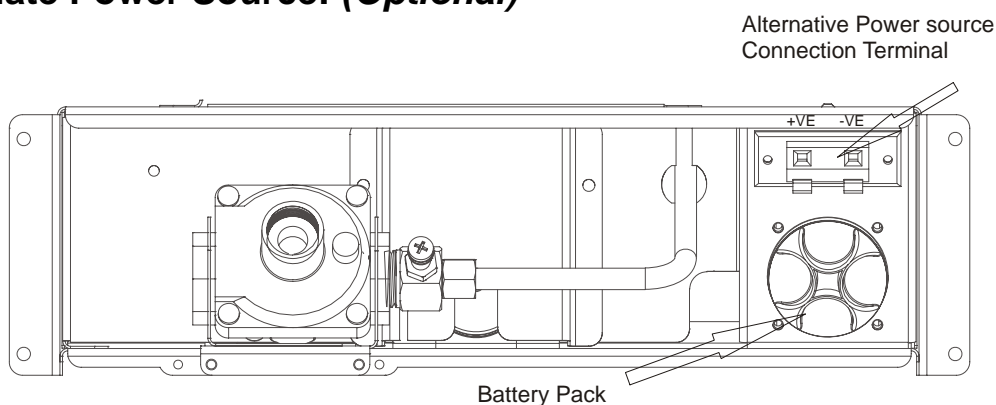

If you wish to connect your outdoor fire to mains electricity instead of using 3x D sized batteries, you may do so using the Alternative Power Source Connection Terminal, located on the control tray above the battery pack, as shown above.

You will need to purchase a transformer capable of 5v DC output, with a minimum of 1.3 Amp capacity. Connect the transformer to the fire by putting the Positive wire into the Red terminal of the control tray, then connect the Negative wire to the Black terminal.

**THIS MUST ONLY BE DONE BY AN AUTHOURIZED ELECTRICIAN**

### 3.0 Creating the Cavity:

The dimensioned drawing below shows the size of opening that must be created to install the unit.

### 4.0 Cavity Dimensions:

Ideal Cavity Dimensions		
<b>A</b>	<b>B</b>	<b>C</b>
39 <sup>13</sup> / <sub>16</sub> "	23"	13"

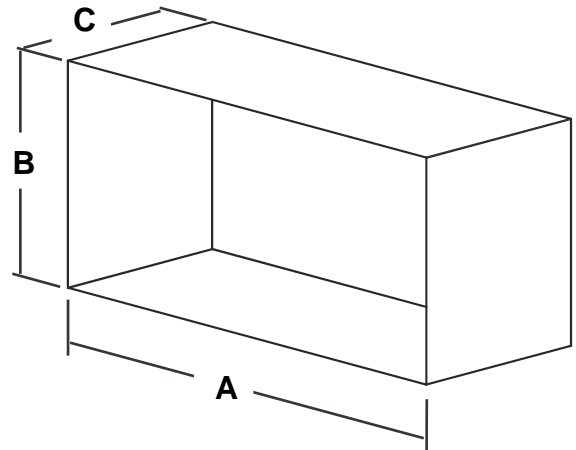

4.1 Where possible, it is recommended that the cavity is made slightly larger than the above dimensions to give the installer the maximum amount of space to work in.

### 4.2 Clearances:

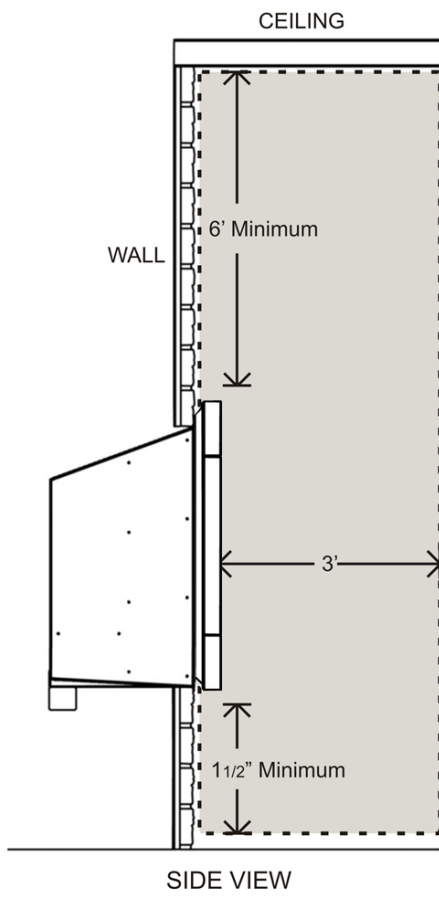

Minimum clearance distance between the ceiling and fascia to be no less than 6'.

Warning: Under no circumstances should any object such as people, pets, furniture, etc. be closer than 3 feet in front of the escea EF5000.

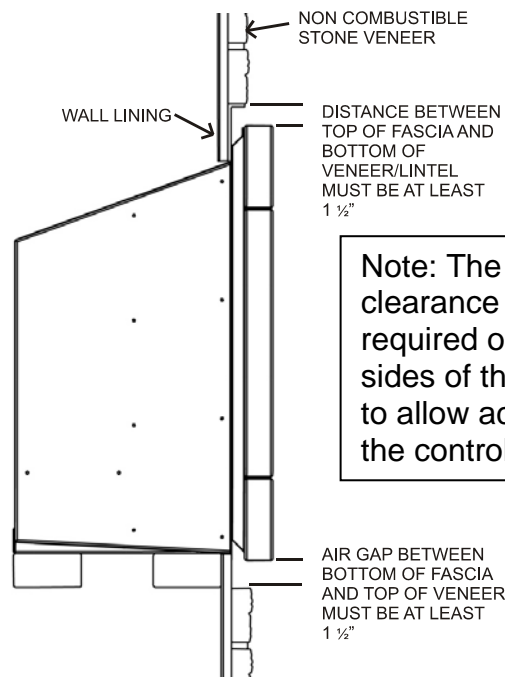

**Note:** The 1 1/2" clearance is also required on the sides of the fascia to allow access to the control panel.

## 5.0 Wall cladding around fire:

- 5.1 The temperature of the wall directly above the heater will get hot and hence may discolour paint finishes.
- 5.2 Some dark coloured exhaust stains may also become visible directly above the fire due to exhaust. In most cases this can be cleaned off with water and a brush.

## 6.0 Minimum install height:

The fire has ventilation gaps behind the fascia at the top and bottom. These must not be blocked, so ensure there is a gap of at least 1 1/2" between the bottom of the fascia and anything below.

## 7.0 Types of Installation:

This appliance shall only be used in an open-air situation with natural ventilation, without stagnant areas, where gas leakage and products of combustion are rapidly dispersed by wind and natural convection.

Certain materials or items, when placed under or near the appliance, will be subjected to radiant heat and could become damaged.

Typically an outdoor space is not enclosed but, any enclosure in which the appliance is used shall comply with one of the following:

- An enclosure with walls on all sides, but at least one permanent opening at ground level and no overhead cover.

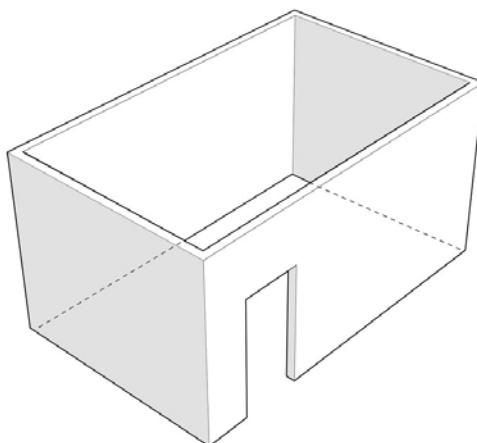

- Within a partial enclosure that includes an overhead cover and no more than two walls.

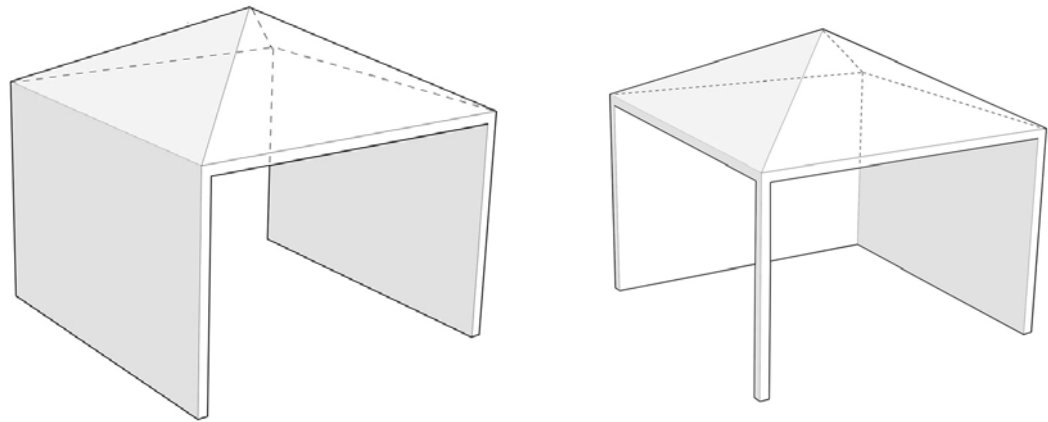

- Within a partial enclosure that includes an overhead cover and more than two walls, the following shall apply:
  - At least 25% of the total wall area is completely open, and
  - At least 30% of the remaining wall area is open and unrestricted

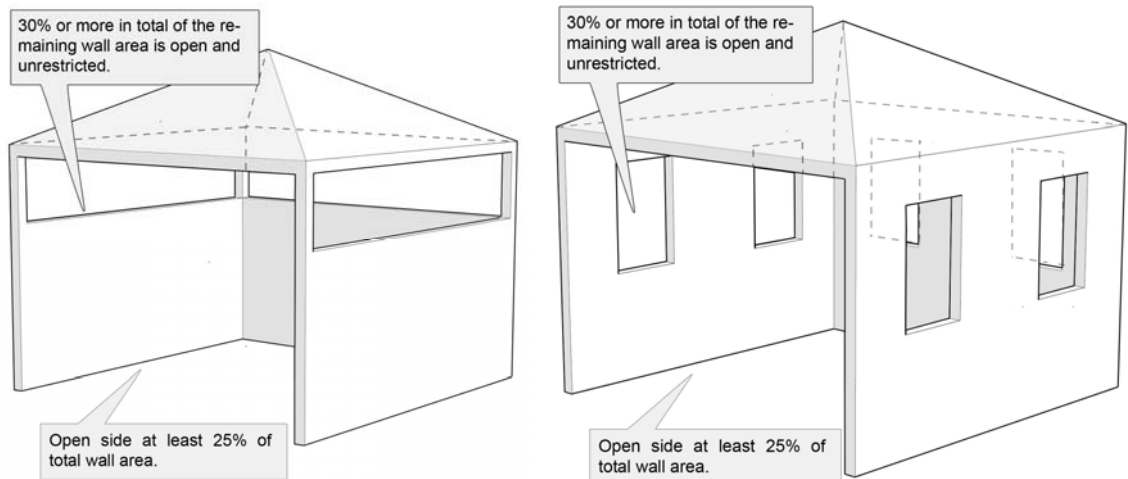

Rectangular areas have been used in the above diagrams, the same principles apply to any other shaped area.

In the case of balconies, at least 20% of the total wall area shall be and remain open and unrestricted.

## 7.1 Corner Installations:

If a cavity is to be created in a corner, the following drawings give the minimum sized interior wall dimensions possible.

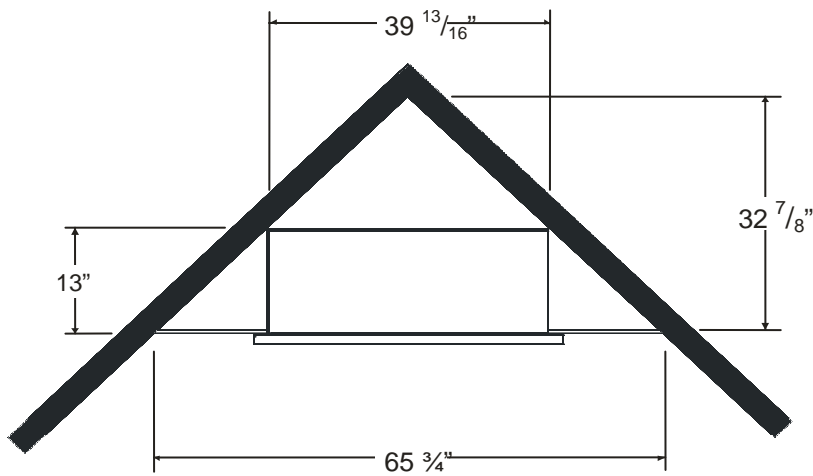

Note:

Allowances need to be made for the internal cladding of the cavity.

Dimensions of the cavity in this diagram represent the internal size only.

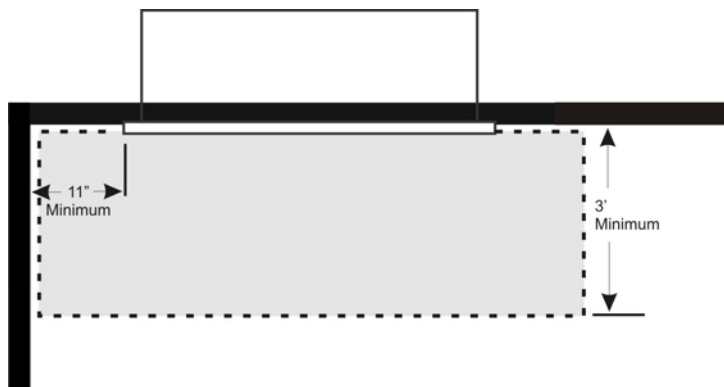

Minimum clearance distance between adjacent wall and fascia to be no less than 11".

## 8.0 Laying Gas Pipe:

Gas pipe should be sized as per the requirements of your local council. The pipe sizing must be sufficient to deliver the following volume of gas to the heater with all other gas appliances in the home running at the same time;

$$EF5000 = 60 \text{ Mj/hr} - 56,000 \text{ Btu/hr}$$

It is highly recommended to install an easily accessible isolating shut off valve (ball valve) along the gas line to the EF5000 unit.

- 8.1 Solid pipe should be run to the inside lower left hand side of the fire. Insert the supplied rubber plug and cut it as shown below to allow the gas pipe to pass through, keeping the plug as air-tight as possible.

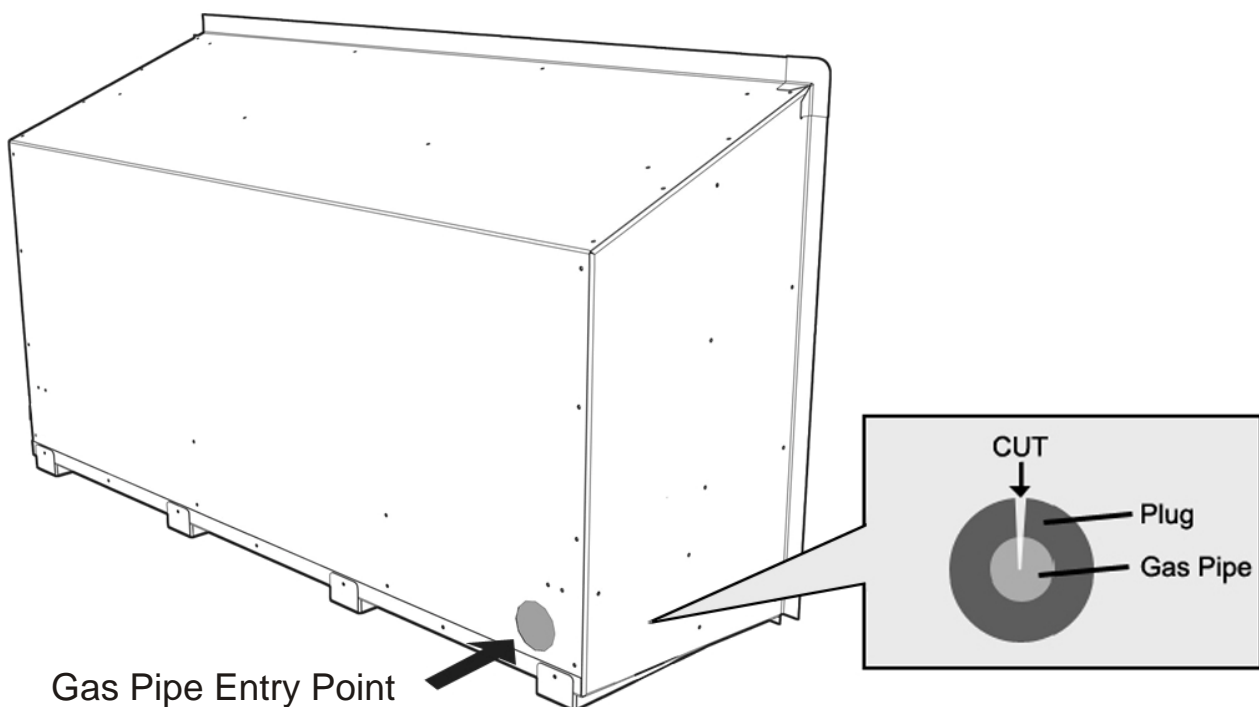

- 8.2 It is required by law that an approved shut off valve (not supplied) be installed in the line between the EF5000 Gas Fire and the gas supply.
- 8.3 All hoses and gas pipes must be located out of pathways where people may trip over it and must not be in areas where the hose may be subject to accidental damage.

## 9.0 Fixing the fire into the cavity:

To fix the fire to the cavity, first drill 4 to 6 (3/16" diameter) holes in the *outer flange* (as shaded grey in the picture below) in locations which will give you the most support from the cavity framework behind, and evenly spaced around the flange. Using the supplied Stainless Steel screws, fasten the fire to the cavity through these drilled holes.

Ensure that the fire is securely located and free from movement.

### Suggested location of screws for mounting

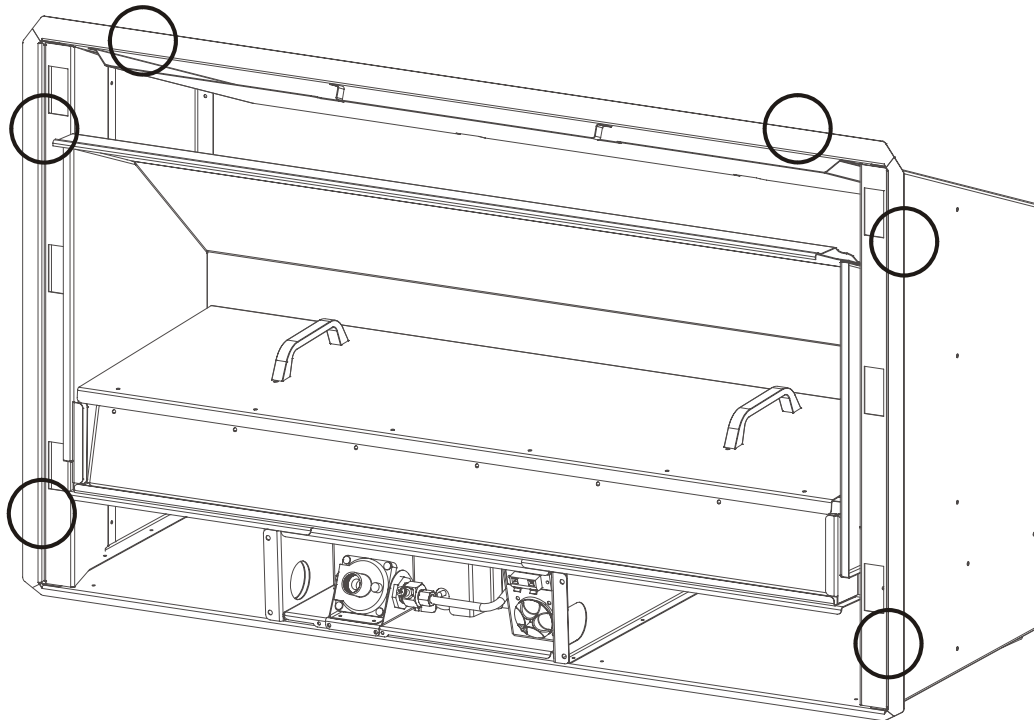

## 10.0 Connecting the Gas Pipe:

When the fire unit has been pushed into position and secured the gas pipe can be connected to the inlet side of the appliance regulator (BSP thread) at the front center of the fire. The hose and pipe assembly should have been tested prior to this as per section 8.2

- 10.1 The regulator that is supplied in the fire **MUST NOT BE REMOVED**. Removal of the regulator, or replacing it with one not intended for use with an Escea EF5000, will void the limited appliance warranty.
- 10.2 The EF5000 must be isolated from the gas supply piping system during any pressure testing of that system at test pressures in excess of ½ psi (14"WC).

The gas fireplace and its individual shutoff valve must be disconnected from the gas supply piping during any pressure testing of that system at test pressures in excess of ½ psi (3.5 kPa – 14" w.c.).

## 11.0 Connecting the power supply and Touch panel:

- 11.1 The Touch Panel and Power Isolating Switch are located in the RH side of the Fascia.
- 11.2 The Touch Panel socket and Isolating Switch socket plugs into the 5 pin plug lead situated at the front RH side of the fire. Push them together until they 'click',

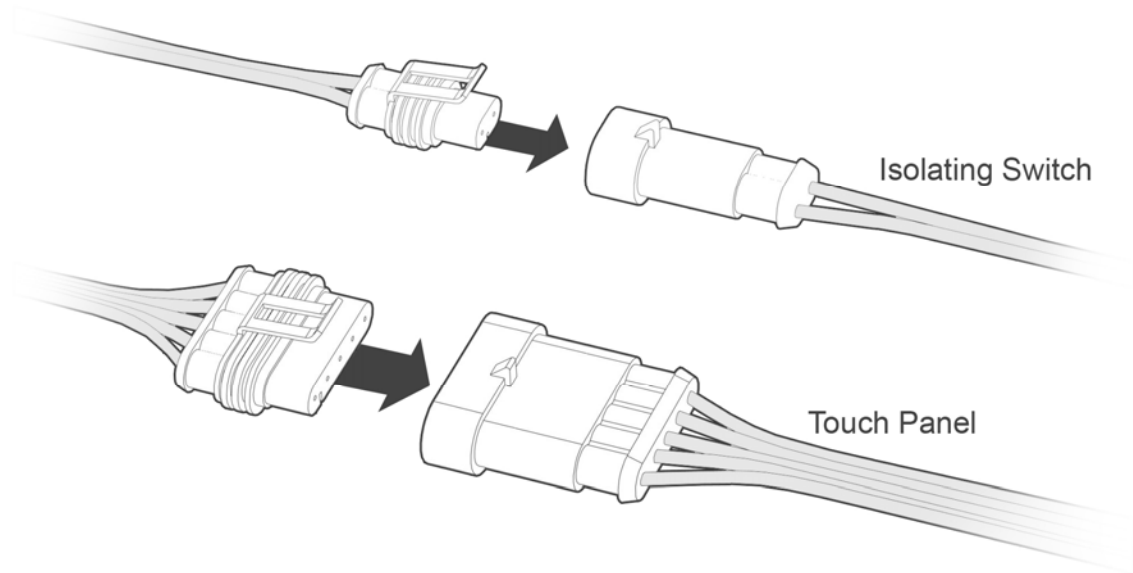

## 12.0 Testing of the Touch panel and spark ignition:

*IMPORTANT: Before the operating pressure can be checked and the fascia fitted, The touch panel and spark ignition must be tested.*

- 12.1 This can be done with the gas supply either turned on or off. With the power supply and touch panel connected, Lean the fascia Right end up beside the fire and run through the steps for igniting the pilot (refer to section 17.0 for instructions).

### 13.0 Checking Operating Pressure:

This is done at the regulator located at the lower front of the appliance.

- 13.1 This must be done before the fascia has been fitted.
- 13.2 The manifold pressure has been factory set. Please check that the manifold pressure is as listed below by checking at the outlet test point.
- 13.3 Replace operating test point screw and leak test the test point.

<b>EF5000 Pressure table</b>		
	<b>Propane</b>	<b>Natural Gas</b>
Maximum Inlet pressure	20"wc	20"wc
Minimum inlet pressure	10"wc	5.5"wc
Manifold Pressure	10"wc	5"wc

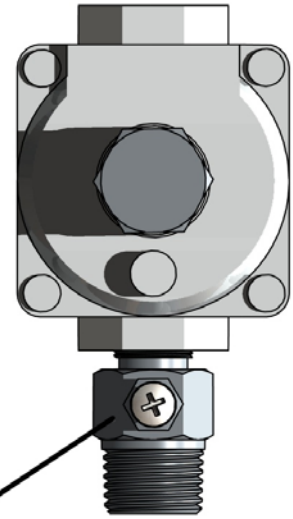

Operating pressure test point

## 14.0 Assembly of stone cartridge:

The glass which fits inside in the stone Cartridge has been packaged to protect it during transit, and can be found inside the firebox. Insert the glass strip into the stone cartridge as shown to the right, between the two metal flanges and push it all the way to the bottom. A bag of pebbles (River Stones) are also supplied, use these to fill the stone cartridge.

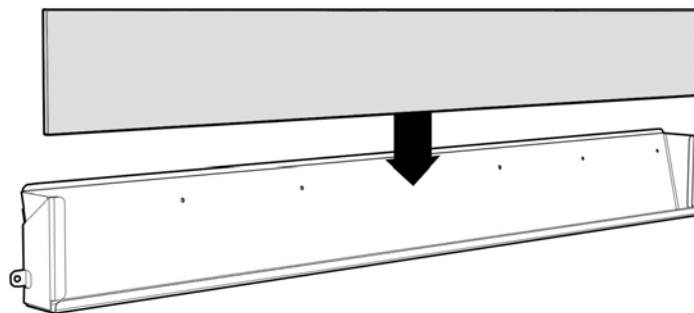

- 14.1 With the glass in position, fix the stone cartridge to the fire by using the two supplied screws in the location shown below. Do this before the fascia is fitted.

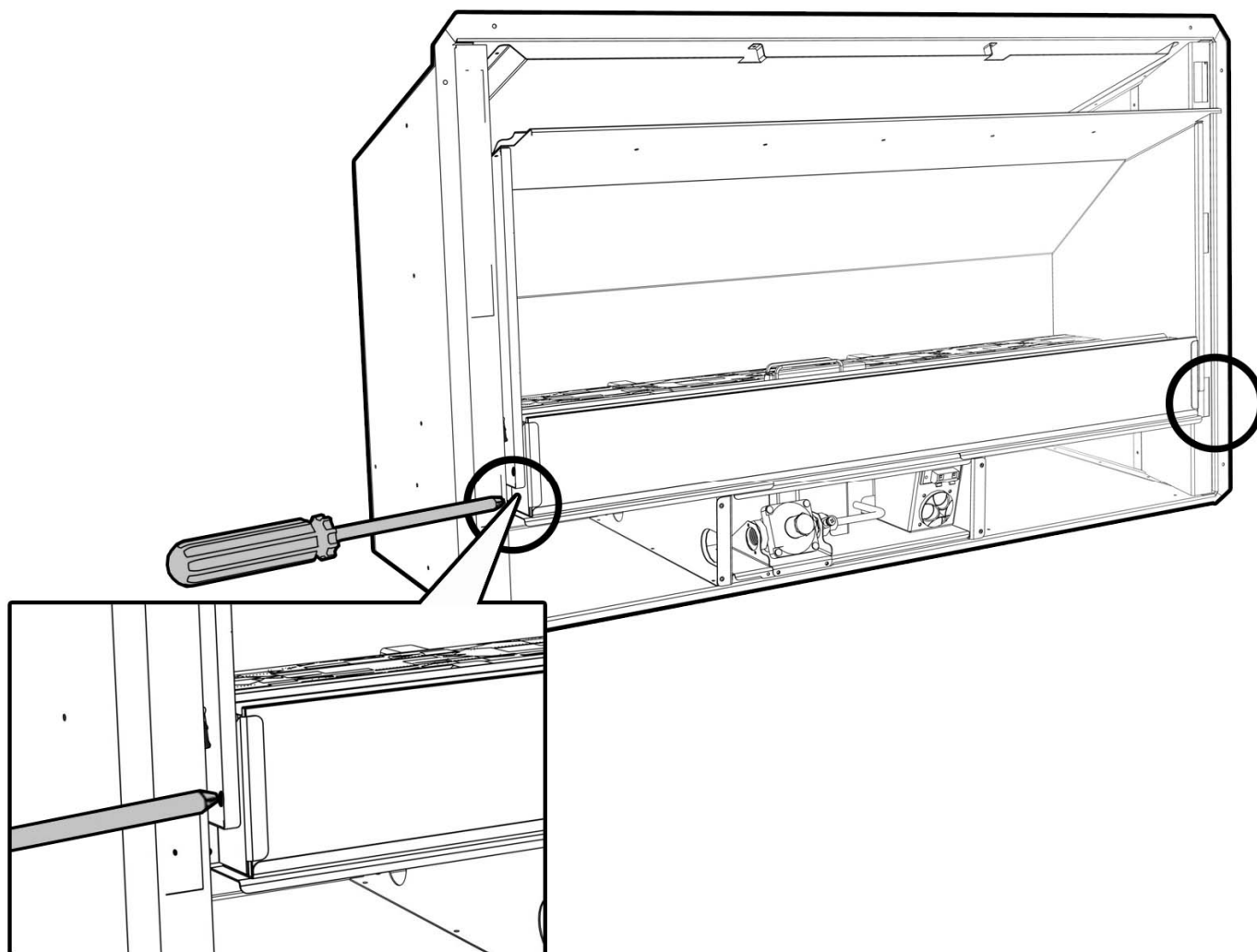

## 15.0 Fitting the Fascia:

Before fitting the fascia, the hooks must be attached using the screws provided. Ensure the two wires connecting the fascia to the fire are securely connected, as per section 11.0.

The EF5000 Stainless Steel fascia is attached to the combustion box by four 'hooks' on the corners of the fascia.

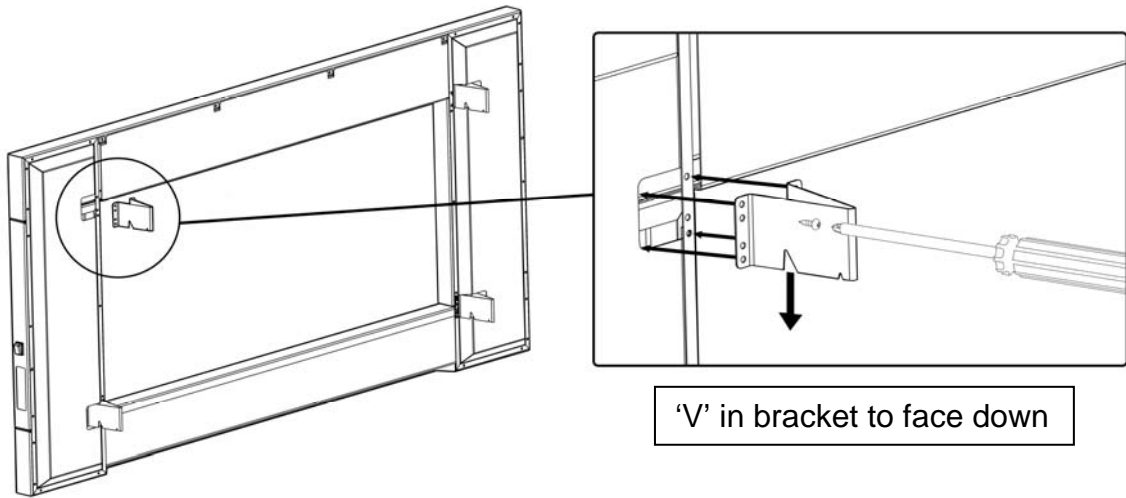

Line up the hooks with the receptacles on the Outdoor Fire pictured below, and push the fascia into position.

- 15.1 When you have pushed the fascia in as far as it will go, briefly push down on the fascia to secure the fascia into position.

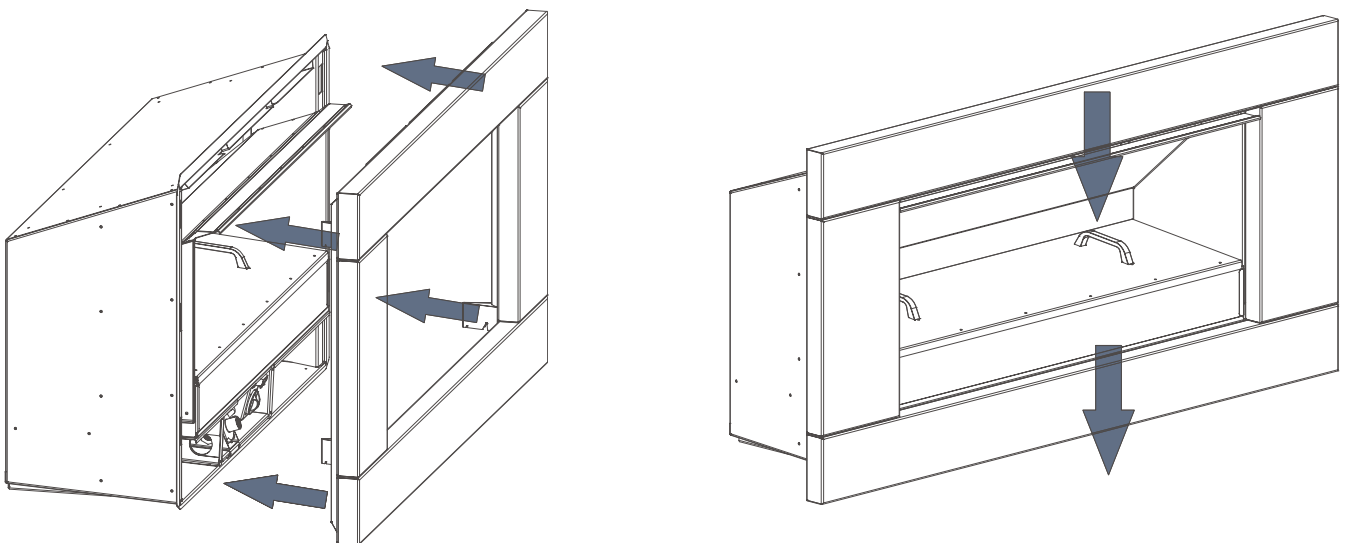

## 16.0 Placement of ceramic stones:

EF5000 fuel beds should be evenly spread out with a maximum one layer of media. Do not heap or mound the fuel bed media, but attempt to get an even spread across the top of the burners.



Ceramic stones

River stones

16.1 **UNDER NO CIRCUMSTANCES SHOULD THE SUPPLIED SMALL STONE PEBBLES (RIVER STONES) BE PLACED ON THE BURNERS. THEY ARE FOR USE INSIDE THE STONE CARTRIDGE ONLY**

16.2 The Weather Cover supplied protects the stones and burners. This must be replaced when the fire is not in use.

16.3 To fit the weather cover ensure fire is off and cooled, and place the front edge on the glass at the front of the fire, the rear flange of the Weather Cover will rest on the burner supports behind the rear burner. To remove, lift the Weather Cover upwards and then towards yourself.

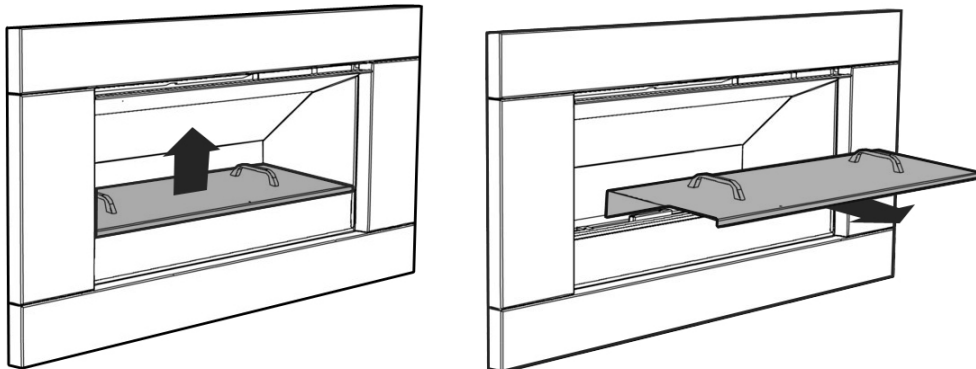

16.4 The fire **MUST NOT** be operated while the cover is fitted.

16.5 The cover **MUST NOT** be fitted while the fire is hot. A cooling period of 30 minutes must be observed before fitting.

16.6 Objects such as wood, coal, fire logs or any other solid fuels shall not be burned in the gas fireplace.

Under no circumstances should any objects enter the gas fireplace during the start-up or whilst the fire is running.

## 17.0 Operating Instructions:

The EF5000 is operated by the touch control panel located on the Right hand side outer edge of the fascia. The basic operations possible from the touch control are ON/OFF and manual adjustment of the flame height.

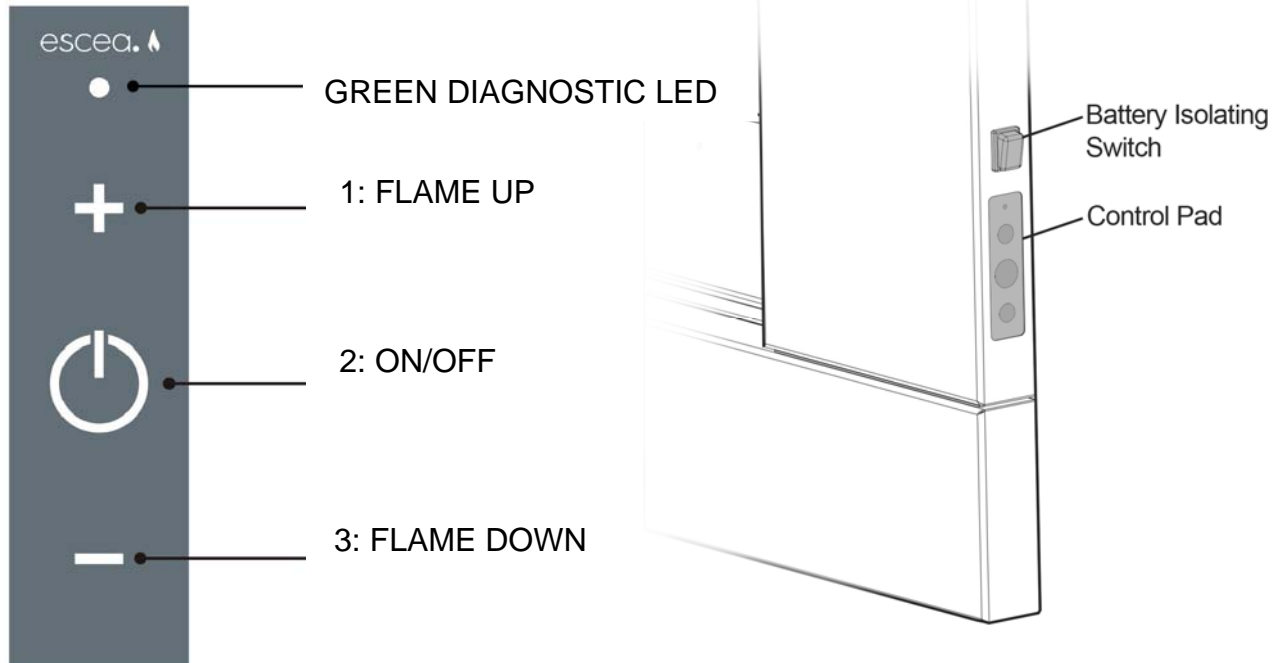

### 17.1 Igniting the pilot flame:

17.2 First turn on the battery isolating switch

**NOTE:** The first time you attempt to ignite the EF5000 after connecting it to a gas supply, will take between 1 and 4 lighting attempts in order to let gas flow through the pipe system and purge all air. To do this, push 'power' to switch the fire on and wait for 12 seconds. If there is a spark but no flame, push 'power' again to switch off (you will hear a click) and then repeat until you get a pilot flame. Alternatively you can flick the battery isolating switch above the control panel off and then on again. This will totally reset the system.

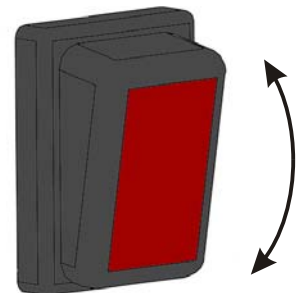

To turn on the fire push the ON/OFF button (2) on the touch control. The pilot will start sparking and gas will start flowing to the pilot which should light and be visible in a few seconds.

17.3 The pilot ignition process takes a duration of 12 seconds. No other button should be pressed during those 12 seconds.

In the event of the pilot not igniting after 12 seconds press the ON/OFF button (2) this will turn the valve and gas off. Now repeat the process from 17.2 until the pilot ignites.

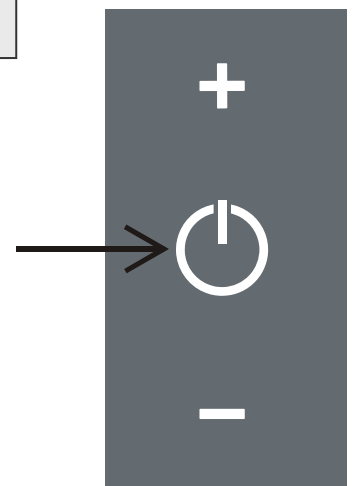

## 17.4 Pilot Flame and Burner Positioning

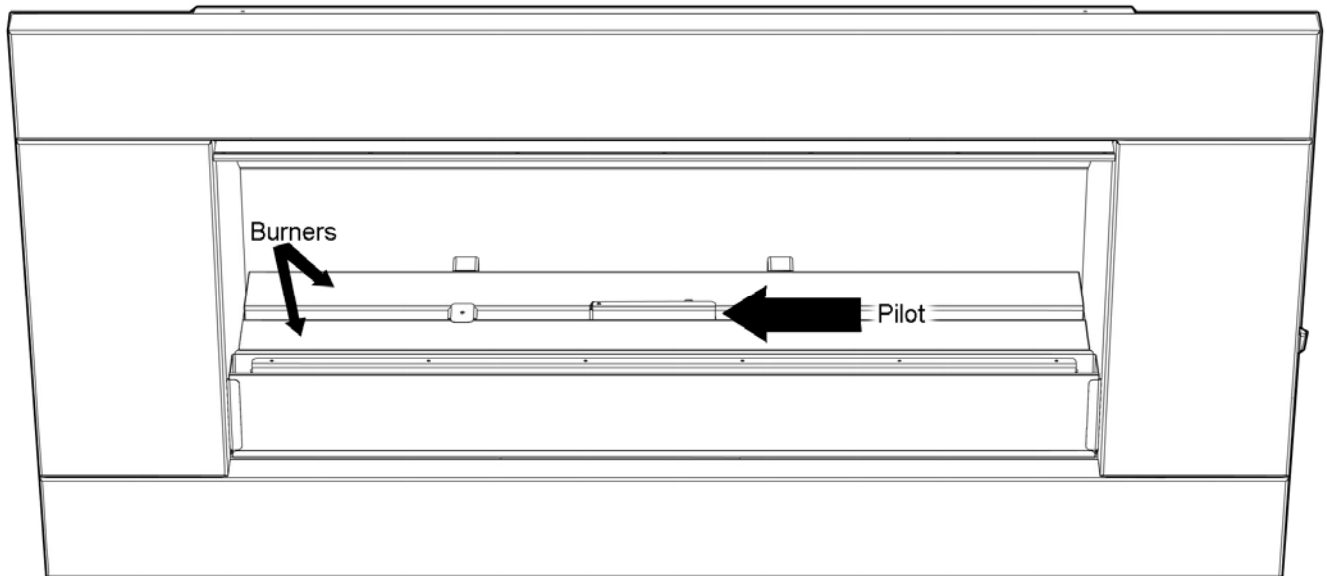

## 17.5 Turning on the main burners

Once the pilot flame has been running for at least 6 seconds press the FLAME UP (1) button to start the gas to the two main burners

17.6 The EF5000 has 4 flame positions: PILOT flame only, LOW burner flame, MEDIUM burner flame and HIGH burner flame.

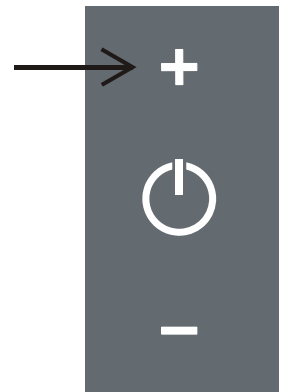

## 17.7 Adjusting the flame height

While the fire is on, push the FLAME UP button (1) or the FLAME DOWN button (3) to increase or decrease the flame height.

17.8 If the FLAME UP button (1) is pushed while the fire is in HIGH burner flame position, nothing will happen. Similarly if the FLAME DOWN button (3) is pushed while fire is in the PILOT flame position, nothing will happen.

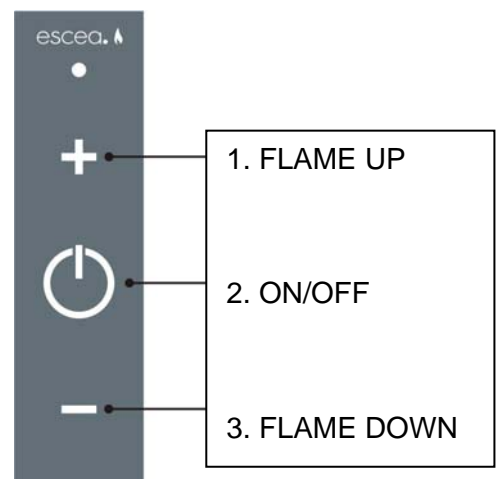

## 17.9 Turning off the fire

To turn the fire off, you must push the ON/OFF button (2) this will shut down the gas flow to the pilot flame and both burners. Then turn off the isolating switch.

## 18.0 Maintenance and Cleaning

The unit must be cold before starting any form of maintenance or cleaning. To remove the glass and stones in the front stone tray simply reverse the steps in section 15.0. The glass can be cleaned using standard window cleaner and the quartz stones can be washed using soapy water

- 18.1 For cleaning the stainless steel fascia the following products are recommended; 3M Stainless steel cleaner, methylated spirits with a clean cloth

For cleaning the powder coated Fascia/ weather cover use soapy water and a sponge or a clean cloth.

Cleaning of the burners and ceramic stones can be carried out using a brush and a dry cloth and should be done at least annually. This will remove carbon or soot build-up.

Periodically the pilot and burners should be checked visually for carbon and soot build-up, consistent flame and clean burning.

- 18.2 Periodical visual checks of the pilot and burner flames should be carried out to ensure consistent flame and clean burning, then turn off the battery isolating switch.

## 19.0 Electrical Schematic

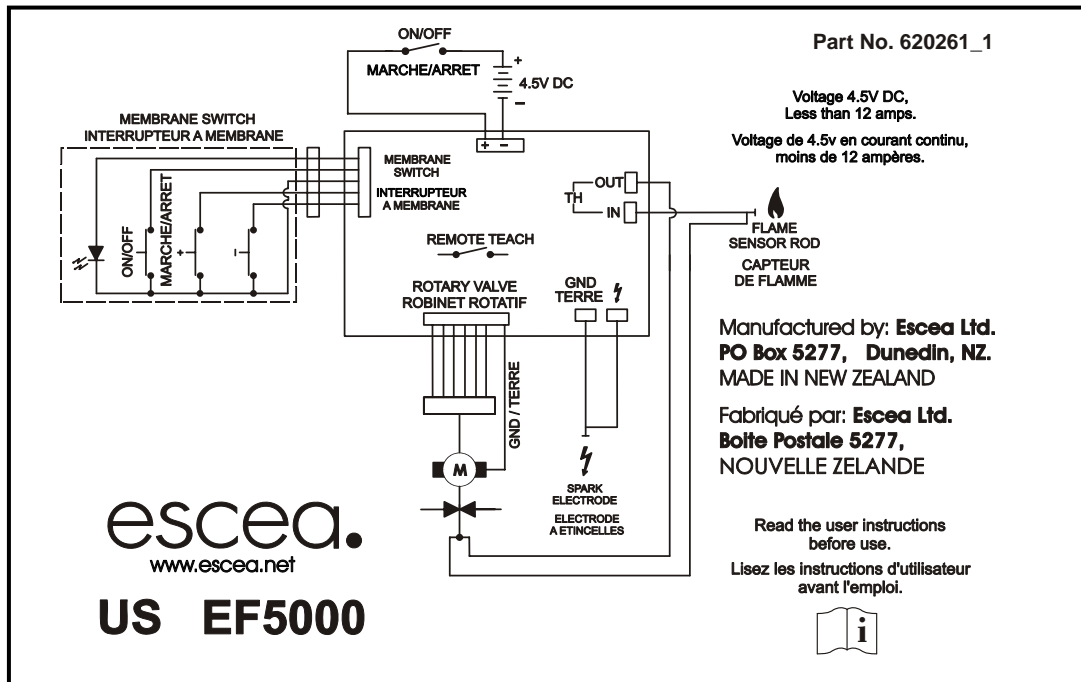

# EF5000 Replacement Parts

Please use part numbers listed if ordering replacement parts.

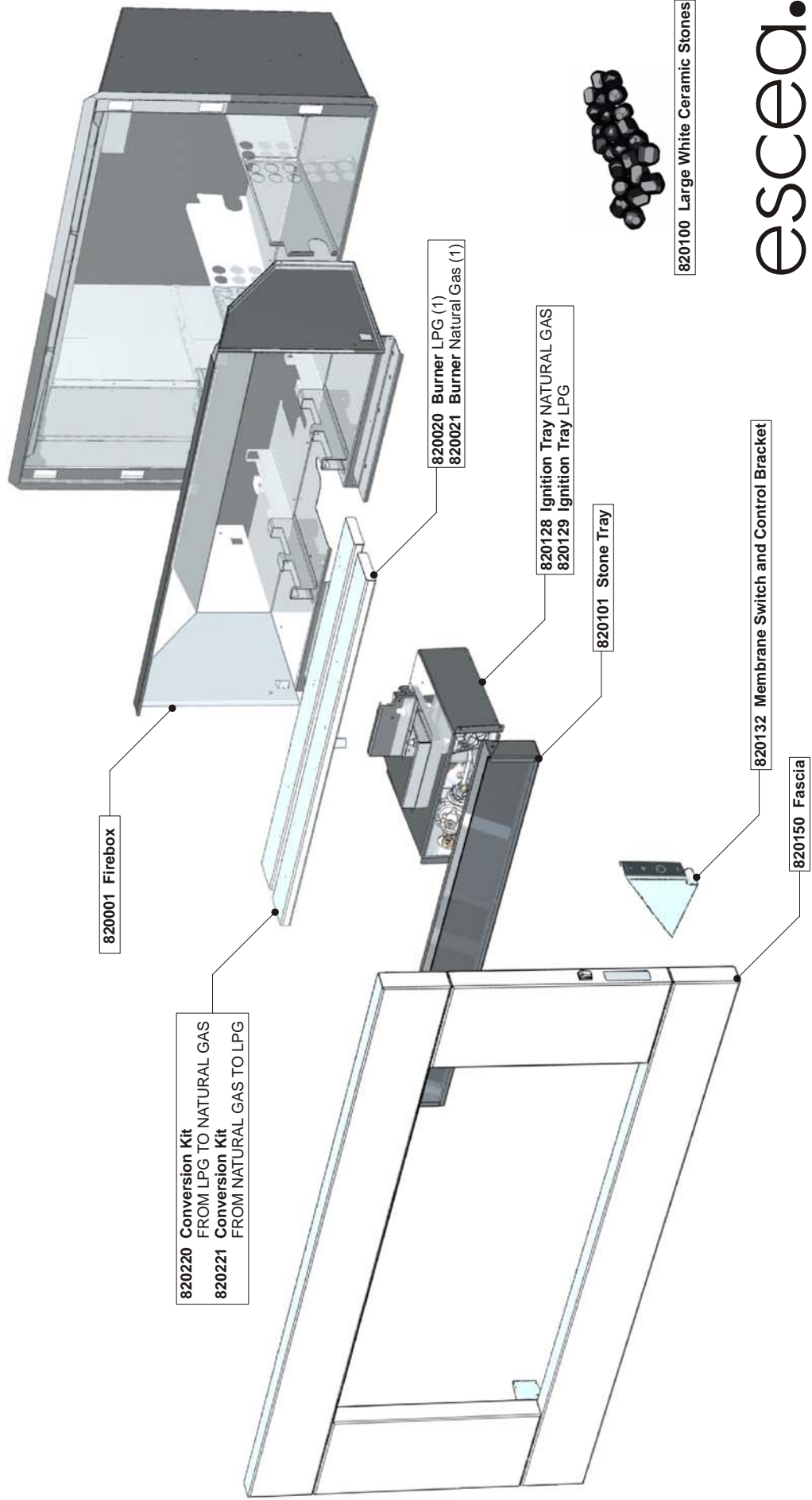

## 19.1 Operation Chart

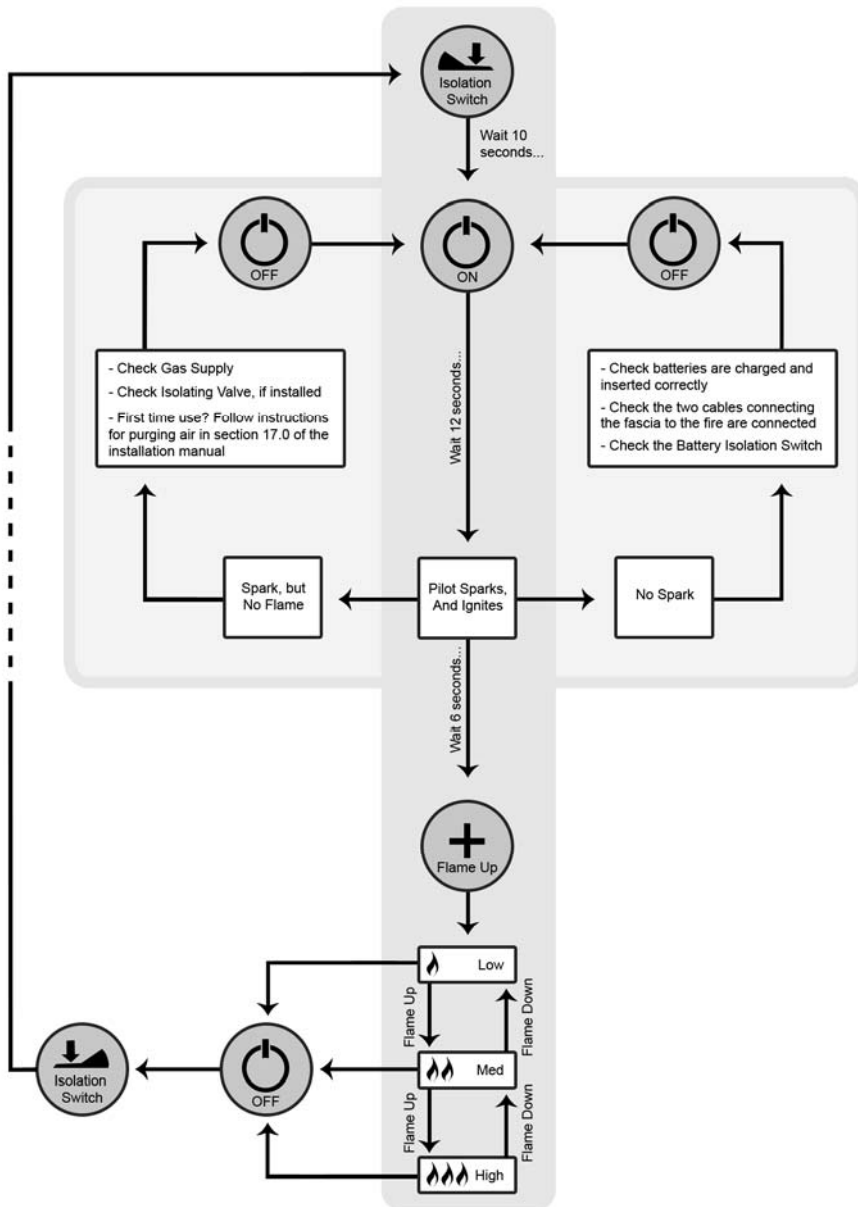

	<b>LPG</b>	<b>Natural Gas</b>
Min. Inlet Pressure	10"wc	5.5"wc
Max Inlet Pressure	20"wc	20"wc
Manifold Pressure	10"wc	5.0"wc
Front Burner Jet Size	0.063"	0.125"
Rear Burner Jet size	0.063"	0.125"
Front Burner Aeration Hole	0.433"	0.236"
Rear Burner Aeration Hole	0.433"	0.236"
BTU	56000	54000

For certification inquiries, please contact [certinfo@csa-international.org](mailto:certinfo@csa-international.org) or contact our Client Services Centre at 1.866.797.4272 or (416) 747-2661

**CSA.**  
**Cleveland, Ohio**  
 8501 East Pleasant Valley Road  
 Cleveland, Ohio, USA, 44131-5575

#### LIMITED WARRANTY:

Provided that the Product is installed as per ESCEA's Installation Manual and the step by step warranty procedure has been followed as per instructions issued by ESCEA, (documented in the Dealer Manual), and the product is operated and maintained in accordance with ESCEA operating and maintenance instructions, then for the first period of twelve (12) months from the date of purchase ESCEA will pay to the dealer who sold the appliance, a pre-determined sum to repair or replace any part of the Product that is deemed by ESCEA to be faulty.

For the second period of twelve (12) months from the date of purchase ESCEA will supply replacement parts only, without charge.

Parts and Labor for the first twelve (12) months:

- a) ESCEA, at its sole discretion and through its dealer, may modify, adjust, repair, or replace the faulty products. The warranty period on parts and labor shall be for twelve (12) months from the date of purchase.
- b) Pre-determined labor costs will only be reimbursed when ESCEA specified procedure has been followed, and ESCEA has authorized service work before it was carried out.

Parts Only for the second twelve (12) months:

- a) ESCEA, at its sole discretion, will provide replacement parts to its dealer for the benefit of an end user. Faulty parts MUST be returned to ESCEA. The parts only warranty period shall be for twelve (12) months and will commence twelve (12) months after the acceptance date of the Products by the ESCEA retailer.

#### General Terms and Exclusions:

1. All repairs made within the Limited Warranty period shall be covered by this Limited Warranty for a period of three (3) months from the date of completion of the repair, or for the remainder of the overall Limited Warranty period, whichever is the longer.
2. If the buyer or any other party modifies any part of the product within the Limited Warranty period without the prior written consent of ESCEA then the Limited Warranty shall be void. ESCEA may, at its sole discretion, decide that the Limited Warranty is void in relation to any part of the product, which has been modified.
3. ESCEA must be notified of all claims under this Limited Warranty as soon as possible, but in any event not later than two (2) weeks of the claimant becoming aware of the circumstance giving rise to the claims.
4. No ESCEA Distributor, retailer, employee or other third party is authorized to make any modification, extension, or addition to this Limited Warranty, whether verbal or written.
5. ESCEA reserves the right to discontinue products or make substitutions, in such event, the buyer may receive a substitute product or a cash refund at ESCEA'S sole discretion, if a replacement for the product covered by this Limited Warranty is no longer available.
6. ESCEA is not responsible for damage arising from failure to follow instructions for the product's installation, maintenance and permitted and proper use. The Limited Warranty does not cover damage caused by use with non-ESCEA products or damage caused by accident, abuse, misuse, weather, fire, flood, earthquake or other external causes. Products where an ESCEA serial number has been removed or defaced or damage caused by incorrect fuel type or flueing are also not covered. Cosmetic damage, including but not limited to paint blemishes, scratches, non structural surface rust, water damage and normal fair wear and tear are not covered as well. Gas Fireplaces require annual service, problems caused by not having this service done such as (but not limited to) dust and debris build up, flat batteries, insects present in burners, incorrect gas pressure and worn thermocouples are also not covered under this warrantee.

#### LIMITATION OF REMEDIES:

##### TO THE EXTENT PERMITTED BY LAW:

This limited warranty, and the remedies set forth above, are exclusive and in lieu of all other warranties, remedies and conditions, whether verbal or written, statutory, express or implied.

Escea specifically disclaims any and all statutory or implied warranties and conditions, including, without limitation, warranties of merchantability, fitness for a particular purpose and warranties against latent defects.

Except as provided herein, Escea is not responsible for direct, special, incidental or consequential loss or damages resulting from any breach of warranty or condition, or under any other legal theory, including but not limited to the loss of any of the following: use; revenue; actual or anticipated profits (including loss of profits on contracts); use of money; anticipated savings; business; opportunity; goodwill; reputation; any or indirect or consequential loss or damage howsoever caused including the replacement or equipment and property.

Some states in Canada and in some States in the United States do not allow the exclusion of incidental or consequential damages, so the above limitation may not apply to buyer.