

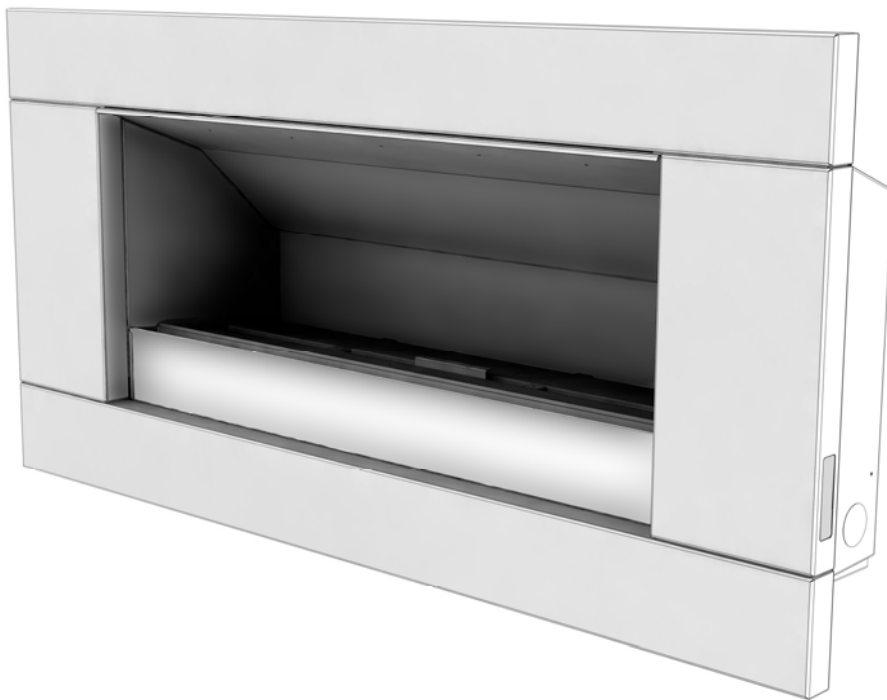

Gas Type Conversion

EF5000 – North America

v 3.0



- **Installation, service and gas conversion must be performed by a qualified installer, service agency or gas supplier.**
- **WARNING: Improper installation, adjustment, alteration, service or maintenance can cause injury or property damage. Read the installation, operating and maintenance instructions thoroughly before installing or servicing this equipment.**

Manufactured by: Escea Ltd, PO Box 5277 Dunedin NZ, Ph: +64 3 478 8220, email: info@escea.net
For contact details of your local Escea distributor or dealer please visit www.escea.net

Warning: Before starting the gas conversion, ensure that the fireplace is cool.

Step one:

Lift the fascia and hang it in the second slot, now you can unplug both of the fascia leads and remove the Fascia from the EF5000 firebox by lifting up and outwards. This will give you access to remove the Burners and Stone tray.

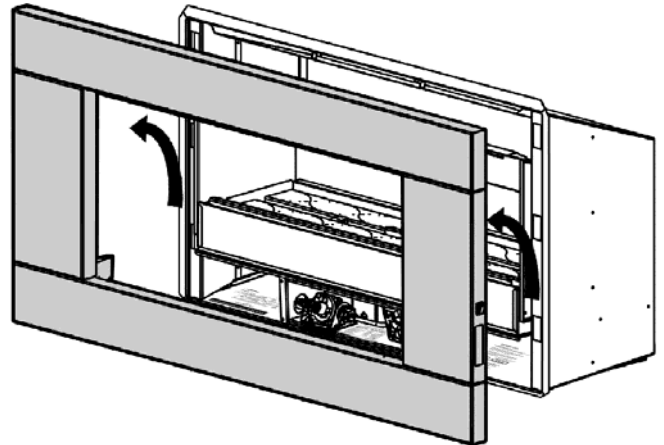

Step two:

Remove all of the coals and the two screws holding the burner clamps in place, remove the clamps.

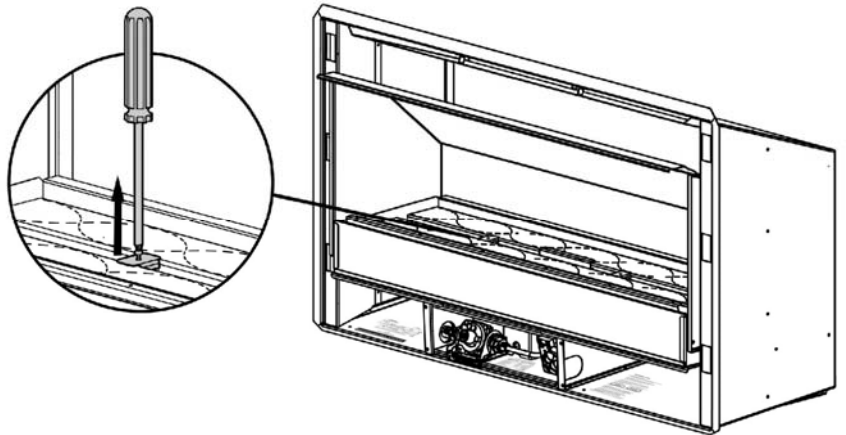

Step three:

Remove the two screws holding the Stone tray in place and lift it out.

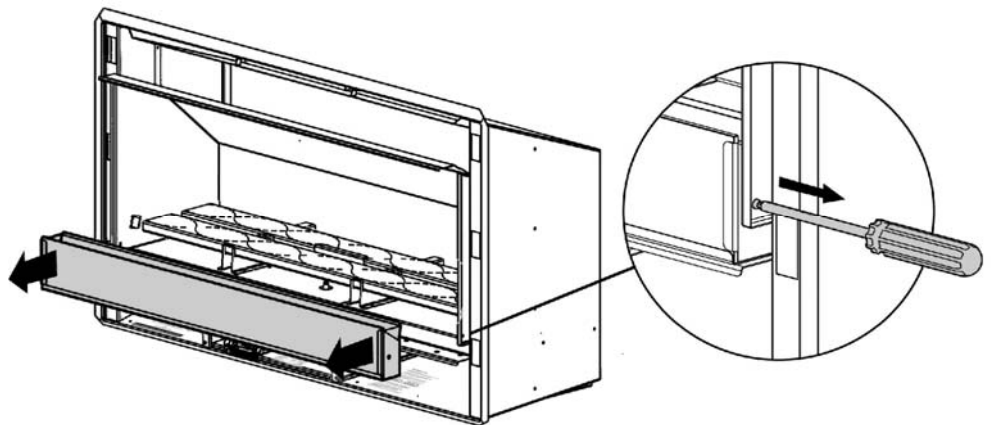

Step four:

Lift out both burners, this will give you access to the jets (spuds).

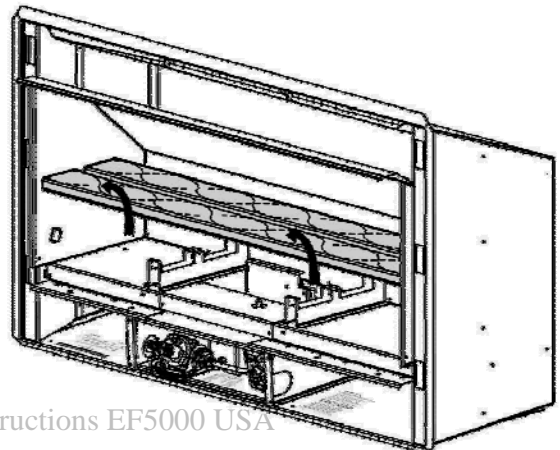

Step five:

Change the two jets with the conversion jets supplied in kitset and bond the new gas label over the old at the bottom tray of the engine.

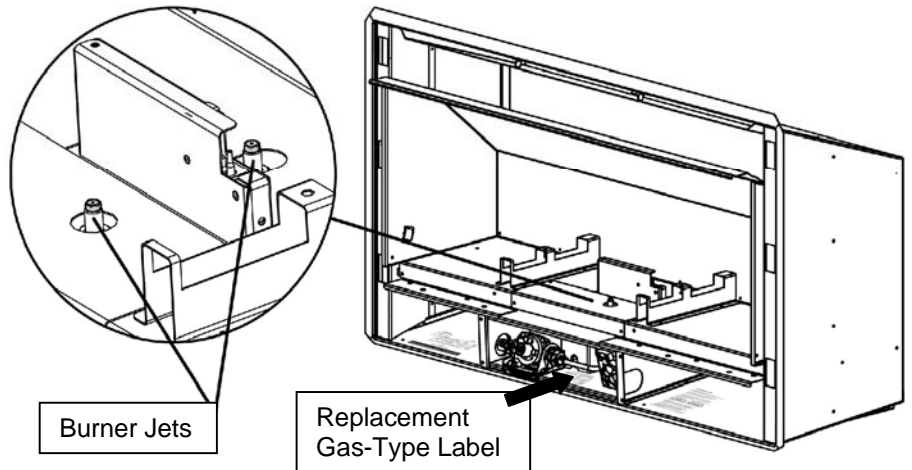

Step six:

To change regulator pressure settings from Propane (LPG) to Natural gas simply unscrew the top cap off the regulator and pull the plunger from it. Then re-insert on the opposite side and screw the assembly back in the stack.

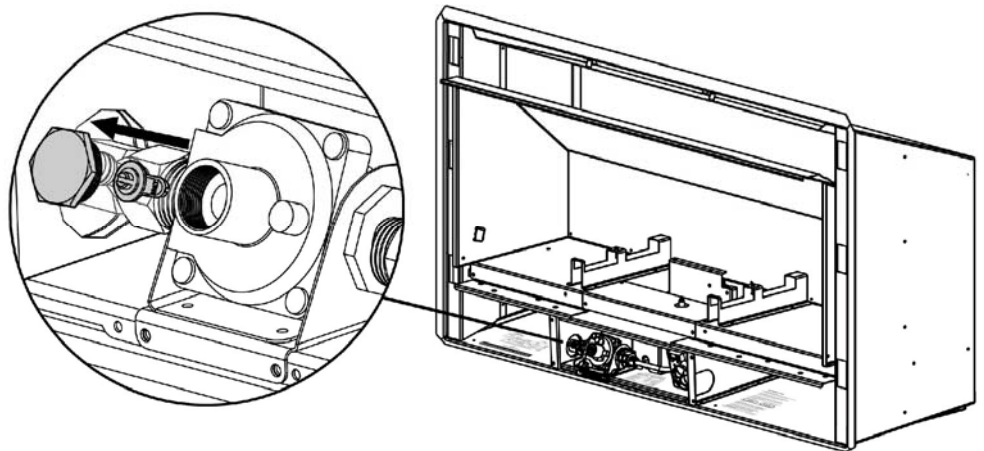

The pictures on the right show how the plunger should be orientated when re-inserted into the regulator.

It is important that the plunger is clipped into the cap before re-inserting into the regulator.

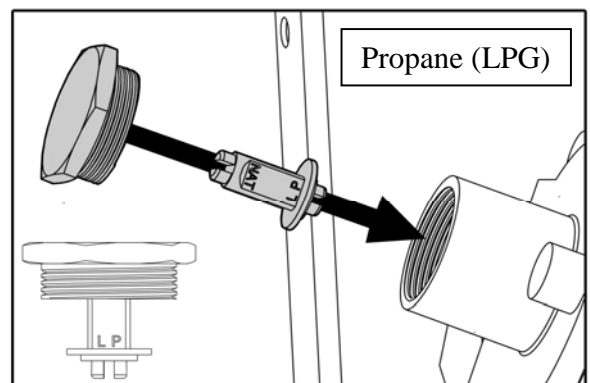
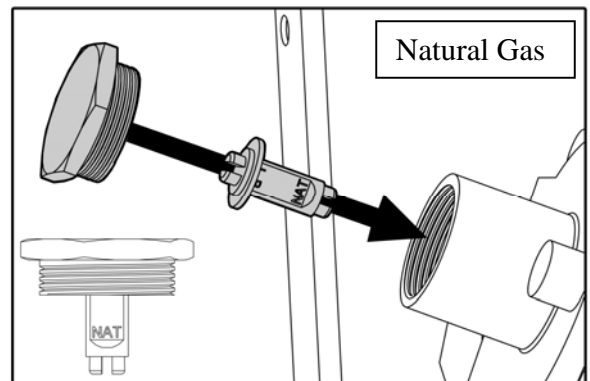

	Natural Gas	Propane
KPa	1.0	2.3

Note: If you have been supplied with a new pair of conversion burners, skip step seven and continue with step eight.

If you have been supplied with only the restrictor sleeves then continue with step seven.

Step seven.

For Propane to Natural gas conversion you will need to fit the natural gas restrictor sleeve. These slide over the burner tube on the underside of the burners, and must be screwed into place so that the porting holes line up.

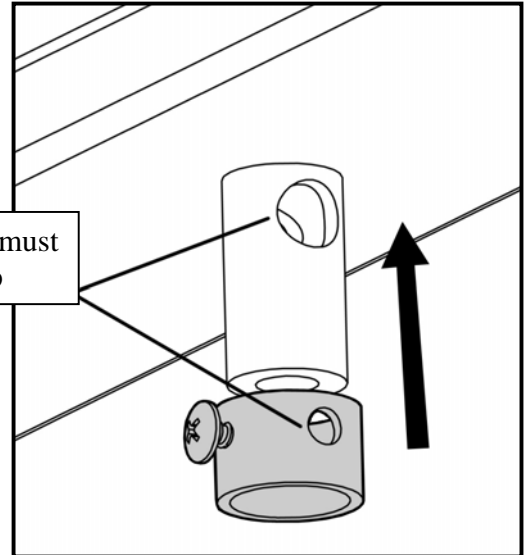

Note: For Natural gas to Propane conversion simply remove the restrictor sleeves from the burners.

Step eight.

- a) Insert the new or modified burners and fix them into place with the burner clamps.
- b) Replace the stone tray and fix it back onto the firebox.
- c) Replace the coals, ensuring you have only one layer. Do not heap or mound the coals.

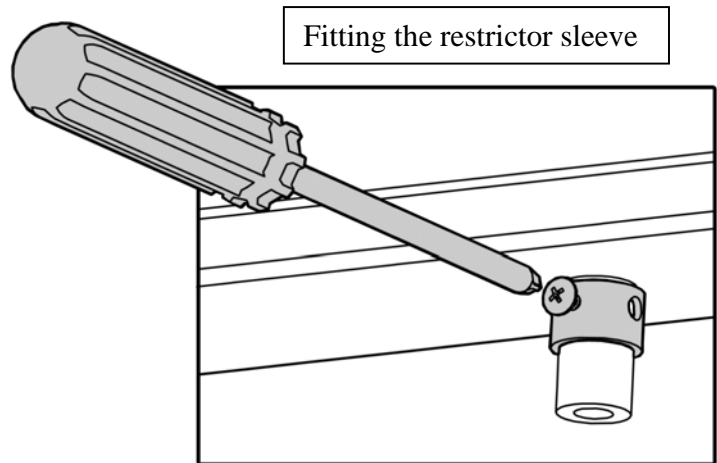

Step nine.

Re-attach the fascia power supply leads. Push them together until they 'click'. Line up the hooks with the receptacles on the Firebox, take advantage of the first slot in the hook where you can rest the fascia before you push the fascia into position.

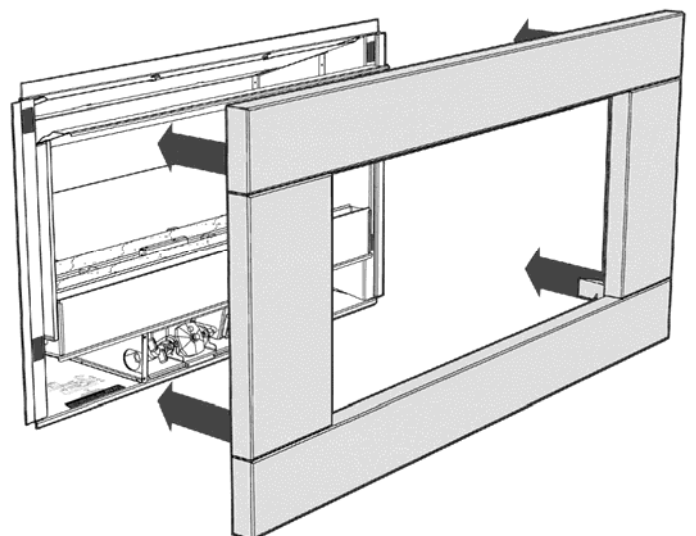

Step ten.

When you have pushed the fascia in as far as it will go, briefly push down on the fascia to secure the fascia into position.

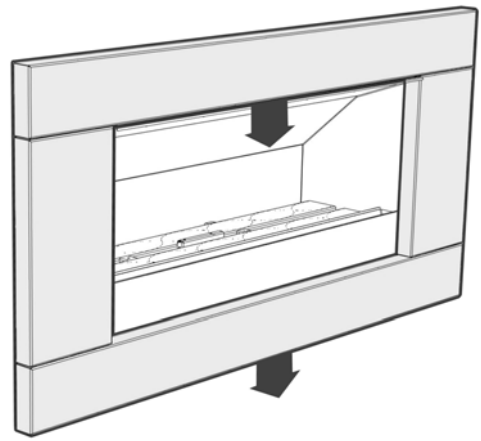

Operation Chart.

Once the fire has been re-assembled, test the fire to ensure it is running correctly.

