

# escea.

## GAS FIREPLACE USER GUIDE



# ST900

## NORTH AMERICA

Ce manuel est disponible en Français sur demande

[www.escea.net](http://www.escea.net)

630169\_3\_Manual\_User\_ST900\_US\_R-emotion

### **WARNING**



**HOT GLASS WILL  
CAUSE BURNS.**

**DO NOT TOUCH GLASS  
UNTIL COOLED.**

**NEVER ALLOW CHILDREN  
TO TOUCH GLASS**

Any installation or service work carried out on this appliance must only be done by a licenced or qualified service person.

The data plate for this appliance, containing technical information and specifications, can be found to the right of the control tray, near the base of the fireplace. To access this, the fascia must be removed.

Escea recommends the ST900 is inspected and serviced by a licenced or qualified service person once every twelve (12) months.

DO NOT PLACE ARTICLES OR FURNISHINGS ON OR AGAINST THIS APPLIANCE.

DO NOT OPERATE THE FIREPLACE IF THE GLASS HAS BEEN BROKEN, DAMAGED OR IT IS NOT PROPERLY POSITIONED/HOOKED ONTO THE FIREPLACE.

DO NOT OPERATE THE FIREPLACE WITH THE FASCIA PANELS REMOVED.

THIS APPLIANCE IS NOT INTENDED FOR USE BY YOUNG CHILDREN OR INFIRM PERSONS UNLESS THEY HAVE BEEN ADEQUATELY SUPERVISED BY A RESPONSIBLE PERSON TO ENSURE THAT THEY CAN USE THE APPLIANCE SAFELY.

THIS APPLIANCE MUST BE INSTALLED IN ACCORDANCE WITH THE MANUFACTURERS WRITTEN INSTRUCTIONS.

THE GLASS SURFACE ON THE FRONT OF THE FIREPLACE IS CONSIDERED A WORKING SURFACE, AND AS SUCH IS HOT AND CARE MUST BE TAKEN NOT TO TOUCH THIS SURFACE. IT IS RECOMMENDED A SECONDARY GUARD IS FITTED IN PLACES WHERE THERE ARE YOUNG CHILDREN OR AGED OR INFIRM PERSONS.

CURTAINS SHOULD NOT BE POSITIONED ABOVE THE FIREPLACE AND ANY PROTRUDING LEDGES MUST NOT COME WITHIN THE MINIMUM DISTANCES SPECIFIED IN SECTION 5.1 OF THE INSTALLATION MANUAL SUPPLIED WITH THIS APPLIANCE.

YOUNG CHILDREN SHOULD BE CAREFULLY SUPERVISED WHEN THEY ARE IN THE SAME ROOM AS THE APPLIANCE. TODDLERS, YOUNG CHILDREN AND OTHERS MAY BE SUSCEPTIBLE TO ACCIDENTAL CONTACT BURNS. A PHYSICAL BARRIER IS RECOMMENDED IF THERE ARE AT RISK INDIVIDUALS IN THE HOUSE. TO RESTRICT ACCESS TO A FIREPLACE OR STOVE, INSTALL AN ADJUSTABLE SAFETY GATE TO KEEP TODDLERS, YOUNG CHILDREN AND OTHER AT RISK INDIVIDUAL OUT OF THE ROOM AND AWAY FROM HOT SURFACES

# Contents

## > **Basic Operation**

Turning the ST900 on	1
Setting the Control Mode	2
Locking the Remote Control	5
Operation from the touch pad	5

## > **Clearances** 6

## > **Cleaning and Maintenance** 8

## > **Normal operating Sounds and Smells** 10

## > **Warranty Information** 11

The ST900 electronic control system is designed to work within the temperature range of 0°C to 70°C, with a humidity level that is non condensing. This is to ensure safe operation of the electronic and gas control system.

If the fireplace is subjected to an environment with temperatures very close to or exceeding these temperature limits (irrespective of if the fireplace is on or off at the time) the fireplace may not start up until the temperature returns back to within the operating range.

To remedy this the environmental temperature should be addressed and the fireplace control system given time to adjust accordingly. The fireplace should then function correctly.

# 1 Basic Operation

The ST900 remote control allows you to turn ON and OFF the fire, control the flame height in the Manual mode, or control the room temperature in the Thermostat mode. The remote has a maximum range of 10 meters, and because the remote works by radio frequency, it does not need to be aimed at the ST900 for it to operate.

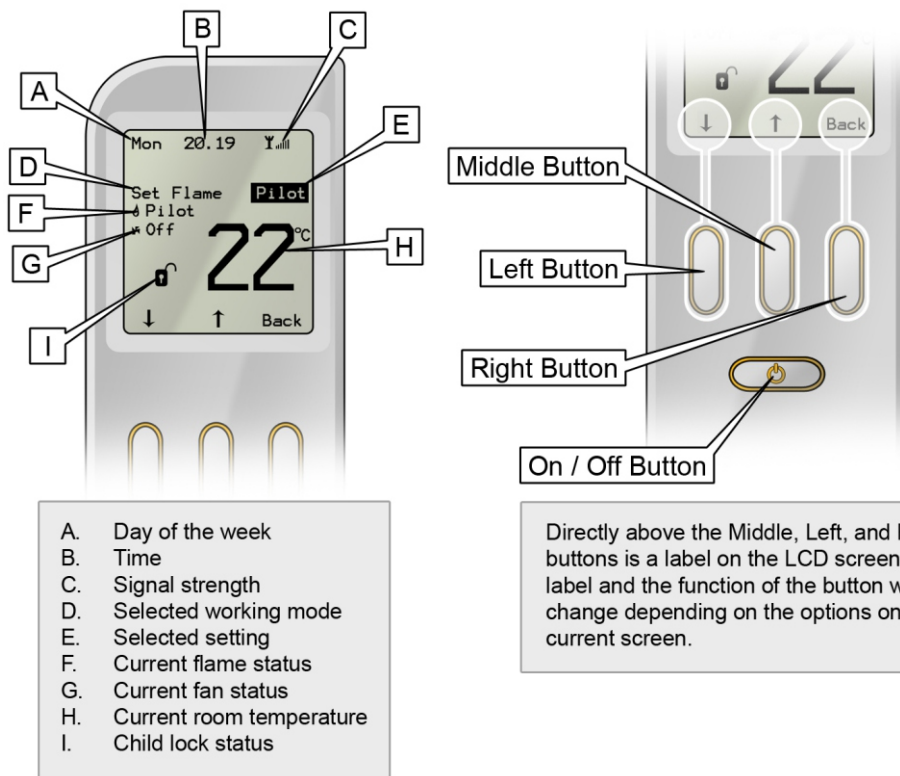

## **Switching on the ST900**

When first powered the remote starts at the OFF screen (it is possible that the remote is locked in the OFF screen: to unlock it just press the button below Unlock, and then OK).

Switching on: Once the remote is unlocked, press On (left button) and OK (middle button). A beep from the control unit will be heard, and the ignition process starts (the pilot will start sparking and gas will start flowing to the pilot, which should then be lit within a few seconds).

If the pilot flame fails to ignite, you must turn OFF the ST900 from the remote and start the process of turning it ON again.

## Switching off the ST900

To turn off the fire, push the OFF button, to shut down the gas flow to the fire and switch it off. The OFF display will now appear in the display.

## Setting the control mode for the fireplace:

There are three different modes for controlling the appliance:

- > **Manual**
- > **Automatic**
- > **Program**

Automatic mode allows you to set a temperature, while in manual mode the flame level may be set to HIGH, MEDIUM, LOW & PILOT. Program mode offers automatic temperature control for specific times of the day.

In the initial screen when the remote is turned on, three options are available: AUTO, MANUAL and MENU.

Auto and Manual are two of the three different modes for controlling the appliance with the remote.

## Manual mode:

If Manual is pressed, Pilot appears as the selected setting. In the bottom row, ↓ and ↑ appear, indicating that the flame level can be changed by just pressing the left or middle button. There are four possible flame positions: Pilot flame, Low flame, Medium flame and High flame. Pressing Back (right button), returns to the initial screen. Note that a Safety temperature can be previously set in the configuration menu. This specifies the maximum the maximum permitted room temperature. This temperature can never be set higher than 40°C (104 °F).



**Automatic mode:**

If Auto is pressed in the initial screen, 25°C (77 ° F) appears as the desired temperature in the selected setting. In the bottom row, ↓ and ↑ appear, indicating that we can change the desired temperature value by just pressing the left or middle button. In auto mode the appliance heats until this temperature is reached. Limits are 0-37°C (32-99°F).



Pressing Back (right button), returns to the initial screen.

In this mode the main burner can be switched on and off.

**Program mode:**

By default the program mode is not enabled. To enable program mode, enter configuration mode by pressing and holding the OFF button for 40 seconds, selecting “Programming” and selecting “yes” (For more information on configuration mode see the installation manual, section 19.9).

There are two types of program mode: a Daily mode and a Weekly mode. In the daily mode, every day uses the same program. In the weekly mode, every day has its own program, so it is possible have a different program for each day of the week.

In this mode the main burner can be switched on and off (pilot still burning).

*Day programming menu:* (Menu → Adjust Menu → Change Program)

There are 8 menus like this. One for Daily, and the others for each separate day (Monday, Tuesday, Wednesday, Thursday, Friday, Saturday and Sunday).

(Continued next page)

## Program mode (continued)

The daily program screen consists of:

**A:** Selected (including “Daily”). The selected day can be changed by pressing Change (middle button).

**B:** Day schedule graphic. This bar displays the program for the whole day by showing the temperature setting for each hour of the day. To access the day schedule graphic, press ↓ (left button). To change the desired temperature, go to the hour you want to change by pressing → (left button) and then press change (middle button).

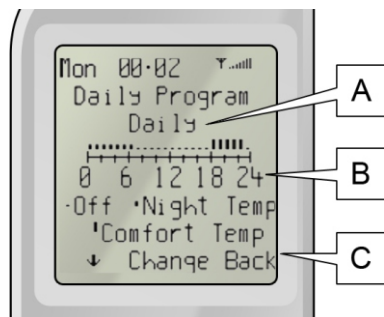

There are 3 temperature settings (bars):

- Off** [Small bar] No temperature control (the appliance is in pilot mode).
- Night Temp** [Medium bar] The night temperature is set as the desired temperature and the appliance will heat until this temperature is reached. To adjust the night temperature press “Menu → Adjust menu → Night” and set the desired temperature.
- Comfort Temp** [Large bar] The comfort temperature is set as the desired temperature and the appliance will heat until this temperature is reached. (High bar). To adjust the comfort temperature press Menu → Adjust menu → Comfort and set the desired temperature.

Finally, to launch the program mode, in the main menu, set Program to On, and select the desired Program Type (Daily or weekly). When activated, the screen will show which of the above temperature settings is currently active, Off, Night, or Comfort. The pilot must remain lit in order for the program to remain running.

## Changing the display from Celsius to Fahrenheit:

Go into Menu → Adjust menu → Unit. Press middle button and then left button for changing units.

**To Lock / Unlock the remote control buttons:**

Go into Menu → Lock. Press middle button and then left button for locking the remote.

To unlock press left button and then middle button.

**Operation from the Touch Pad**

The touch pad is intended to be used for service/diagnostic purposes and to operate the fire in the event that the remote handset becomes lost or inoperative.

If you remove the fascia you will find an electronic touch pad in the lower centre of the fire. The touch pad features the basic operations of the fire: On, off, and manual adjustment of the flame height.

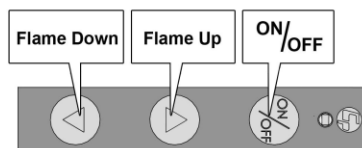

To turn on the ST900, push the ON/OFF button on the touch pad. The system will emit a beep and begin the ignition process, which can take about 20 seconds. Once the start up process is complete, the pilot flame is lit. The ST900 is now in the 'Manual' mode and ready to be used.

While the pilot is lit, press the 'Flame Up' or 'Flame Down' button to alter the flame height. The LED will flash once and the unit will beep to confirm the flame height has been adjusted. The ST900 has 4 flame positions: Pilot only, Low, Medium, and High flame height.

If the 'Flame Up' button is pressed while the unit is in the 'high' flame position, nothing will happen. Similarly, if 'Flame Down' is pressed while the unit is in the 'pilot' flame position, nothing will happen.

To shut down the gas flow to the ST900, press the On/Off button and the LED will begin to blink and the unit will emit a beep.

**DO NOT DROP THE REMOTE.**

Dropping the remote may result in a cracked LCD screen or malfunctioning components. The warranty does not cover damage to the remote sustained by dropping, however replacement remote controls are available.



## Cabinet Clearances

There must be a minimum of 100mm from the sides of the fascia to any protruding side walls or cabinetry.

## Television Positioning Considerations

It is becoming common practice for consumers to mount flat screen TV's above their gas fireplace.

Most TV manufacturers have specified in their instructions that the TV should not be installed on, near or above a heat source. For this reason TV location decisions rest solely with the householder and the manufacturer / distributor will not be held liable for any adverse affects on a TV located near to the ST900 fireplace that may be caused by heat.

The drawings below are suggestions that may be used as a GUIDE for those consumers who do decide to locate their TV above an ST900 gas fire. These drawings show ways to reduce the amount of warm air rising off the fireplace and onto the TV.

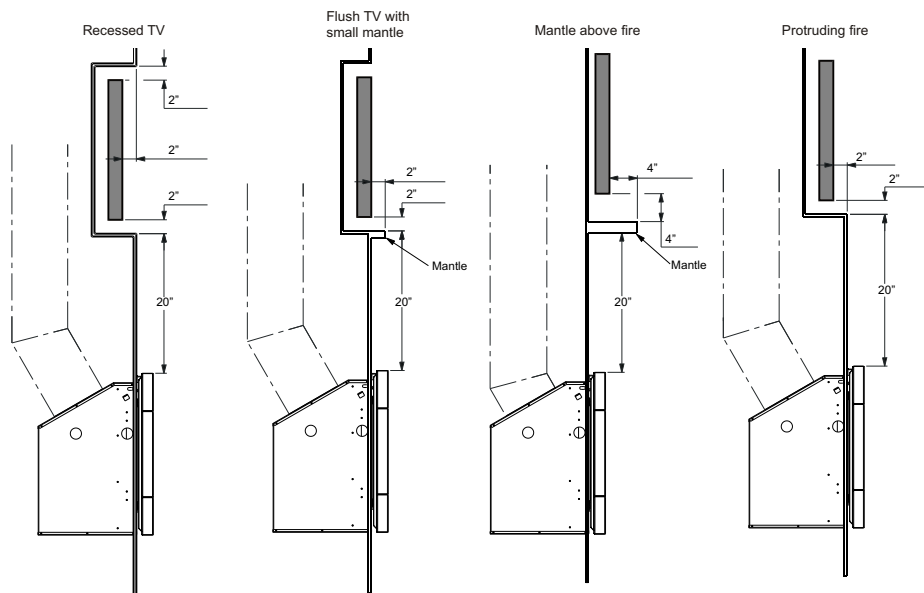

The material that the wall and mantle are made from will also affect the operating temperature of the TV so it is the customers responsibility to satisfy themselves that their TV mounting and mantle design will not exceed the listed maximum operating temperature of their electronic goods.

### Replacing Batteries

When batteries are replaced in either the battery box (inside the fireplace) or in the handset, the unit will require 1 minute afterwards to regain connection.

### ST900 Mantle Clearances

If any part of the installation (mantle, wall or cavity) is constructed from **COMBUSTIBLE** materials, the diagram below shows the maximum allowable size for mantles or protruding surfaces mounted above an ST900

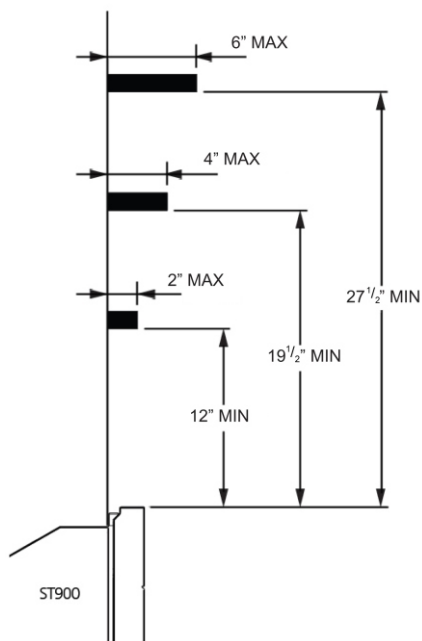

If the entire installation (mantle, wall and cavity) is constructed from **NON-COMBUSTIBLE** materials, then the clearances to mantles or protruding surfaces mounted above an ST900 may be as shown by the shaded area in the diagram below

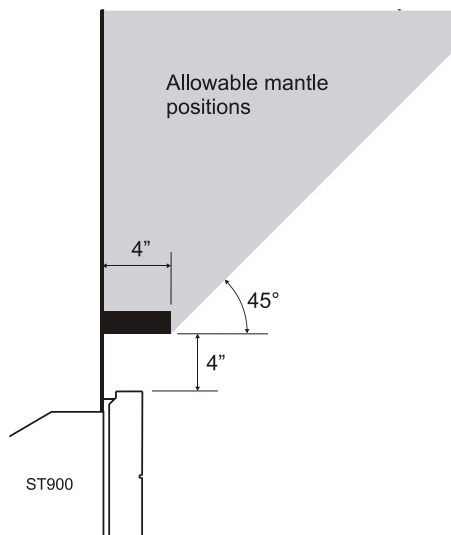

## Annual Servicing

Your ST900 Decorative Gas Fireplace requires that annual service checks be carried out by a Registered Installer to ensure that it will continue to operate in a safe manner.

Please ensure that you schedule annual service checks for your ST900 with your local Registered Installer or service agent.

## Removing the ST900 Fascia

Ensure the fascia is allowed to cool before handling.

The ST900 fascia attaches to the fire by four hooks. To remove the fascia, simply lift it upwards 15-20mm, and pull towards you. Care should always be taken when handling the fascia.

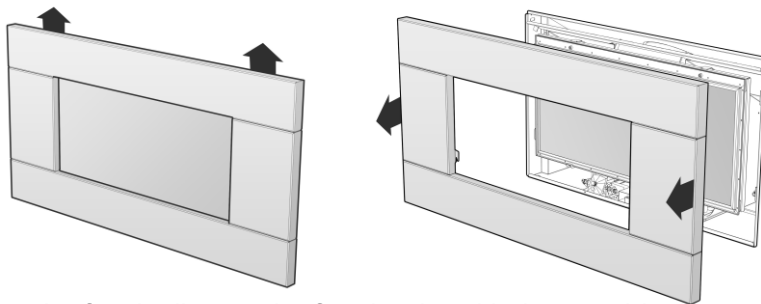

To replace the fascia, line up the four hooks with the matching receptacles on the fire and push the fascia into place and let it drop down, the fascia should now be securely in position

If you have a Velo fascia, the instructions above also apply (lift upwards then outwards), however before removing the fascia the lower trim must be removed

## Removing the ST900 Glass Assembly

Ensure the ST900 is allowed to cool before continuing with the following procedure.

Pull the four hooks shown below towards you and then away from the glass to release the glass frame underneath the hook.

Lift the glass assembly towards you to clear the locating supports and place it flat upon some newspaper or a sheet of cardboard to protect your floor coverings.

# 9 Cleaning and Maintenance

Follow the instructions on page 8 in reverse to refit the glass assembly to the fireplace.

Do not operate the appliance if the glass has been broken, damaged, or the glass is not properly positioned/hooked onto the appliance.

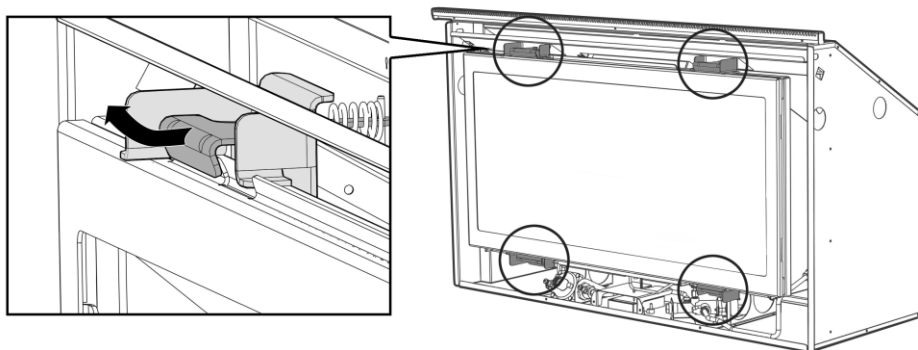

## **Cleaning your ST900**

The unit must be cold before starting any form of maintenance or cleaning.

The glass can be cleaned using standard window cleaner. If you wish to clean the inside of the glass, you can remove the glass assembly by following the instructions on page 8.

Take care while cleaning the glass so as not to interfere with or damage the fibreglass gasket material on the glass assembly.

## **Fuel Bed Media**

Some discolouration of the coals may occur over time, particularly on white coals. The gravel, driftwood, or glass layout and the quantity of material contained therein must not be altered.

*Note: Each time the fire is lit from cold the glass will fog up with condensation. This is normal and the condensation will disappear within a few minutes once the glass heats up.*

## **Sounds**

It is possible that you will hear some sounds from your gas appliance. This is perfectly normal due to the fact that there various types of materials used within your appliance. Listed below are some examples. These are all normal operating sounds and should not be considered as defects in your appliance.

### **Gas Control Valve:**

As the gas control valves turn ON and OFF, a dull clicking sound may be audible, this is normal operation of a valve. When the fire is switched off after being run for a while, there may be popping and fluttering noises as the residual gas in the burner burns away. These are normal and should be no cause for concern.

### **Unit Body / Firebox:**

Different types and thickness' of steel will expand and contract at different rates resulting in some "dull drumming" and "ticking" sounds being heard throughout the cycling process.

## **Smells**

The first few times the unit is operated, the unit may release an odour and the flames may appear orange caused by the curing of the paint, the burning off of the starch in the gas coals and the oils in the metal. This is a temporary curing process which will disappear with use.

**WARRANTY TERMS & CONDITIONS:****LIMITED WARRANTY:**

Provided that the Product is installed as per ESCEA's Installation Manual and the step by step warranty procedure has been followed as per instructions issued by ESCEA, (documented in the Dealer Manual), and the product is operated and maintained in accordance with ESCEA operating and maintenance instructions, then for the first period of twelve (12) months from the date of purchase ESCEA will pay to the dealer who sold the appliance, a pre-determined sum to repair or replace any part of the Product that is deemed by ESCEA to be faulty. For the second period of twelve (12) months from the date of purchase ESCEA will supply replacement parts only, without charge.

**Parts and Labor for the first twelve (12) months:**

- a) ESCEA, at its sole discretion and through its dealer, may modify, adjust, repair, or replace the faulty products. The warranty period on parts and labor shall be for twelve (12) months from the date of purchase.
- b) Pre-determined labor costs will only be reimbursed when ESCEA specified procedure has been followed, and ESCEA has authorized service work before it was carried out.

**Parts Only for the second twelve (12) months:**

- a) ESCEA, at its sole discretion, will provide replacement parts to its dealer for the benefit of an end user. Faulty parts **MUST** be returned to ESCEA. The parts only warranty period shall be for twelve (12) months and will commence twelve (12) months after the acceptance date of the Products by the ESCEA retailer.

**General Terms and Exclusions:**

1. All repairs made within the Limited Warranty period shall be covered by this Limited Warranty for a period of three (3) months from the date of completion of the repair, or for the remainder of the overall Limited Warranty period, whichever is the longer.
2. If the buyer or any other party modifies any part of the product within the Limited Warranty period without the prior written consent of ESCEA then the Limited Warranty shall be void.  
ESCEA may, at its sole discretion, decide that the Limited Warranty is void in relation to any part of the product, which has been modified.

3. ESCEA must be notified of all claims under this Limited Warranty as soon as possible, but in any event not later than two (2) weeks of the claimant becoming aware of the circumstance giving rise to the claims.
4. No ESCEA Distributor, retailer, employee or other third party is authorized to make any modification, extension, or addition to this Limited Warranty, whether verbal or written.
5. ESCEA reserves the right to discontinue products or make substitutions, in such event, the buyer may receive a substitute product or a cash refund at ESCEA'S sole discretion, if a replacement for the product covered by this Limited Warranty is no longer available.
6. ESCEA is not responsible for damage arising from failure to follow instructions for the product's installation, maintenance and permitted and proper use. The Limited Warranty does not cover damage caused by use with non-ESCEA products or damage caused by accident, abuse, misuse, weather, fire, flood, earthquake or other external causes. Products where an ESCEA serial number has been removed or defaced or damage caused by incorrect fuel type or flueing are also not covered. Cosmetic damage, including but not limited to paint blemishes, scratches, non structural surface rust, water damage and normal fair wear and tear are not covered as well. Gas Fireplaces require annual service, problems caused by not having this service done such as (but not limited to) dust and debris build up, flat batteries, insects present in burners, incorrect gas pressure and worn thermocouples are also not covered under this warrantee.

## LIMITATION OF REMEDIES:

### TO THE EXTENT PERMITTED BY LAW:

This limited warranty, and the remedies set forth above, are exclusive and in lieu of all other warranties, remedies and conditions, whether verbal or written, statutory, express or implied.

Escea specifically disclaims any and all statutory or implied warranties and conditions, including, without limitation, warranties of merchantability, fitness for a particular purpose and warranties against latent defects.

Except as provided herein, Escea is not responsible for direct, special, incidental or consequential loss or damages resulting from any breach of warranty or condition, or under any other legal theory, including but not limited to the loss of any of the

following: use; revenue; actual or anticipated profits (including loss of profits on contracts); use of money; anticipated savings; business; opportunity; goodwill; reputation; any or indirect or consequential loss or damage howsoever caused including the replacement or equipment and property.

Some states in Canada and in some States in the United States do not allow the exclusion of incidental or consequential damages, so the above limitation may not apply to buyer.