

SPECIFICATIONS

Flue System	Powered direct-vent, co-linear flue
Flue Termination Locations	Roof or wall mounted terminations
Minimum Flue Length	400mm
Max. Uninsulated Flexible Flue Length	4m
Max. Insulated Flexible Flue Length	NIL
Max. Flue Length	12m
Max. Vertical run below the Fireplace	1.5m
Flue Pipe Sizes	100 and 75mm Ø (ID) flue pipes
Flue Clearance to Combustibles	No clearance required
Flue Bends Allowed	Max. 10 bends in any flue run
Flue Insulation R-Value	N/A
Flue Insulation Service Temp.	N/A
Powerflue Fan Electrical Supply	Supplied from Fireplace
DX Series Ducted Heat System	Compulsory

TECHNICAL INFORMATION

All Escea Gas Fireplaces require Escea's Powered Direct Vent flue system, including a flue terminal, co-linear flexible flue pipes, and flue extensions as needed. **The flue pathway extends from the fireplace to the powerflue terminal in many different configurations, including vertical, horizontal, or a mix of both.** It can pass through walls, floors, roofs, or run to the side or beneath the fireplace. The flue system starts with a standard flue kit and can be extended using PolyPro flue extensions kits up to 12m. Follow the table below.

Flue terminal placement (wall/roof) must adhere to *AS/NZS 5601.1* and *DF Series Install Manual* flue clearances. These guide distances between the terminal and building components. Disregarding these may reduce fireplace/flue performance and jeopardise user safety. Flue fan must remain accessible for servicing. Where PolyPro Flue extensions are used, an exhaust pipe condensate trap is required. This must drain to the foul water/sewer system.

FLUE SELECTION STEPS

1 Flue Terminal

Choose the flue terminal location, on the wall or roof. This dictates the standard flue kit used.

2 Flue Pathway

Establish a pathway from the fireplace to the flue terminal, calculating all vertical and horizontal runs.

3 Flue Components

Establish the method and components required to complete the flue system using the table below.

FLUE SELECTION TABLE

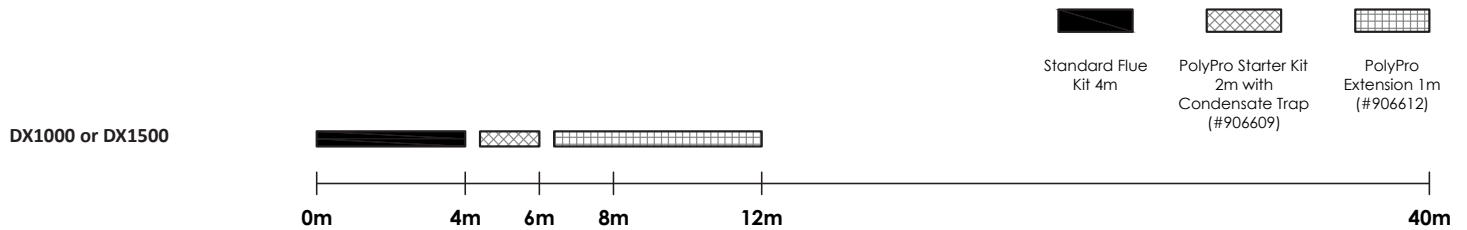

STANDARD FLUE KIT OPTIONS

Horizontal Powerflue (#906641)

For flue terminations through an external wall.

Minimum wall cavity opening requirements:

With wall fixing brackets:

350mm W x 300mm H

Without wall fixing brackets:

296mm W x 296mm H

For dimensions and installation use the link below:

[Horizontal Powerflue Detail](#)

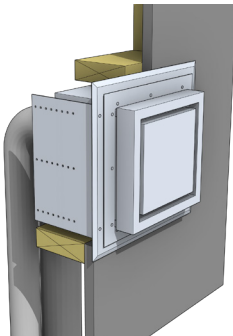

External Vertical Powerflue (#906617)

Used in situations where there is no roof space, or where servicing the flue fan is best undertaken from the roof or chimney top (preferred method).

Min. flue height above roof surface: **500mm**

Liner roof penetration: **225mm Ø**.

For dimensions and installation use the link below:

[External Vertical Powerflue Detail](#)

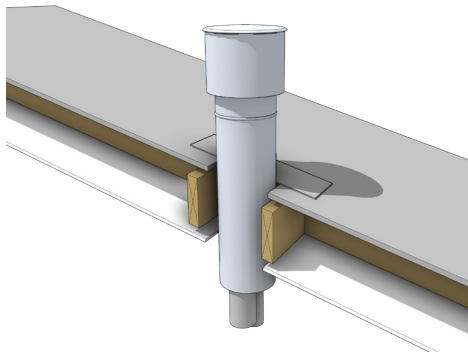

Internal Vertical Powerflue (#906618)

Suitable for installations where the flue fan must be located in a roof space, or in exposed coastal locations.

Min. flue height above roof surface: **500mm**

Liner roof penetration: **225mm Ø**.

For dimensions and installation use the link below:

[Internal Vertical Powerflue Detail](#)

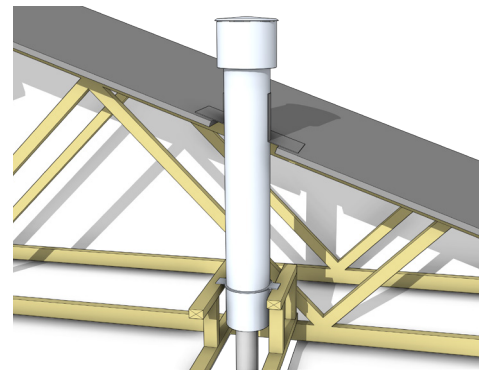

For Installation methods not covered in this document please contact:

Email: aa@escea.com PH (NZ): 0800 17 3000 PH (AU): 1800 460 832

Install Manual and CAD files are available via the QR Code or link:

www.escea.com/technical

Disclaimer:

Dimensions provided are indicative and may not consider all site-specific variations or installation needs. Verify dimensions on-site before manufacturing or construction.