

ESCEA AF700 : TIMBER CAVITY INSTALLATION

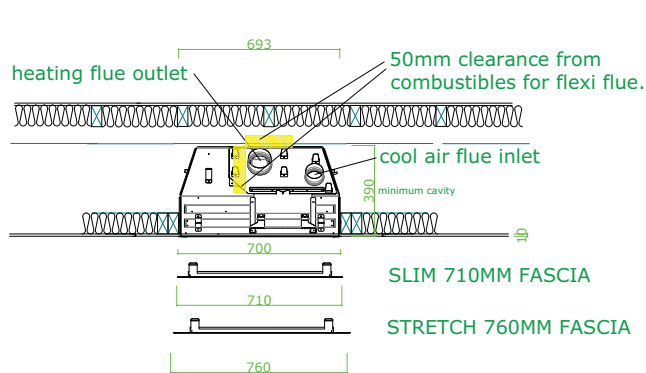

1 PLAN
Scale: 1:20 @ A3

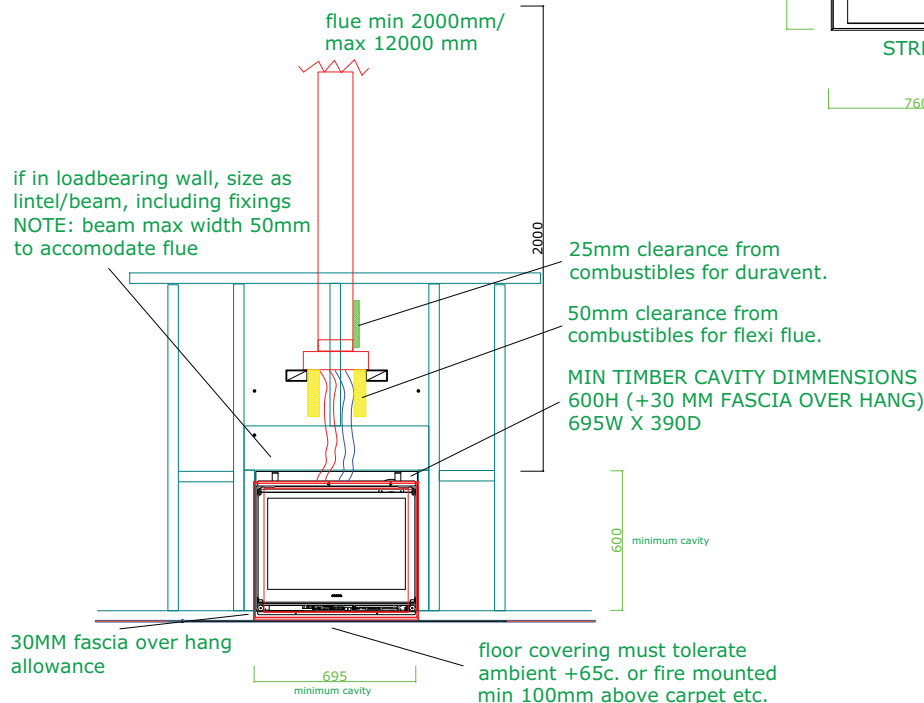
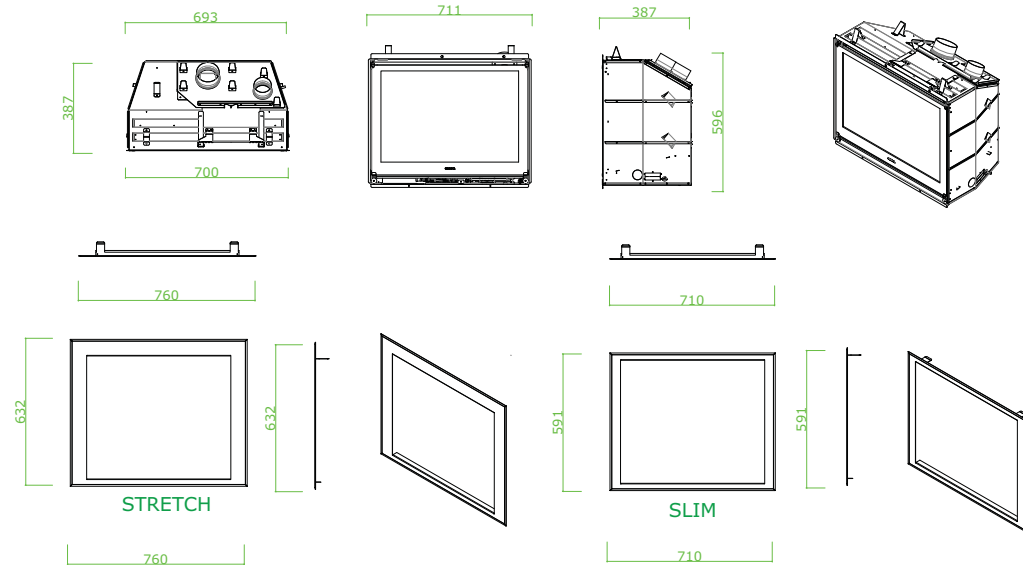

2 ELEVATION
Scale: 1:20 @ A3

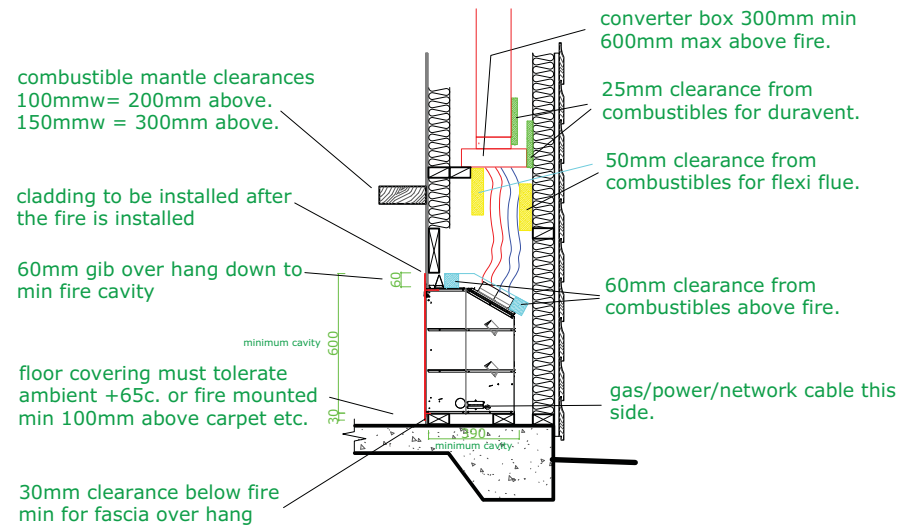

3 CROSS SECTION
Scale: 1:20 @ A3