



Certificate of Compliance

for

SOLID FUEL HEATERS

This is to certify that the appliance stated on this certificate has been tested for Heat Output, Thermal Efficiency, Particulate Emissions and Thermal Clearances in accordance with the Australian / New Zealand Standard(s) detailed below,

Manufacturer	Escea Ltd
Make	Escea.
Model	TFS1000.
Type	Freestanding.
Category	Solid Fuel Burner.
Fuel Type	Hardwood.
Test Report No's:	#0620, accompany with Spectrum Laboratories Ltd opinion letter issued on 10/03/2022.
Maximum Average Heat Output	9.40 kW.
Overall Average Efficiency	61.9 %.
Particulate Emissions Factor	1.00 g/kg.
National Standards	- AS/NZS 4012:2014+A1 - Report # 0620. - AS/NZS 4013:2014 - Report # 0620. - AS/NZS 2918:2018 - Report # 0629.

Spectrum Laboratories Ltd. hereby grants to:

ESCEA Australia PTY Ltd.

of
PO Box 176, Pennant Hills, 1715, Sydney, NSW
Australia

Certificate No.: 0620-2022a
Original Issue Date: 10/03/2022
Re-issue Date: 17/08/2024

Certified Date: 10/03/2022
Expiry Date: **14 August 2025**

Mr. Poyang Chen.
Authorised Signatory of Spectrum Laboratories Limited.
IANZ accreditation number 962

DETAILS OF ACCREDITED LABORATORY.

Spectrum Laboratories Limited.

9B Lady /Ruby Drive, East Tamaki,

Auckland, New Zealand

Service@spectrmlab.co.nz



№ 962

AS/NZS 2918:2018 Appendix B test results

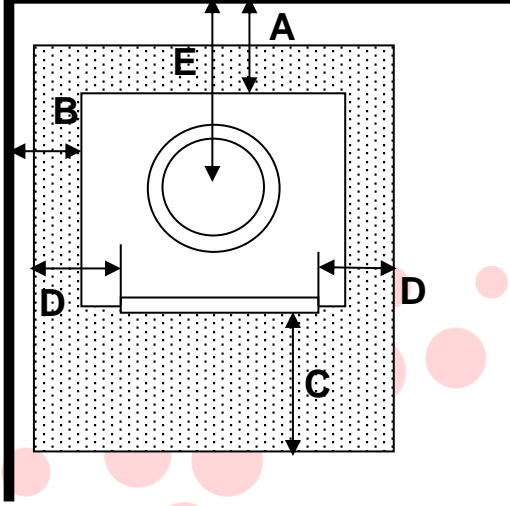
Parallel Position Clearance Distance	Position	Clearance (mm)
	(A) Rear	200
	(B) Side	370
	(C) Floor protector (front)	300
	(D) Floor protector (side)	200
	(E) Flue (rear)	441

Technical Note:

1. The clearance measurement A and B were taken from the distance between walls and closest point of the appliance, C was measured from the front of the fuel-loading opening to the edge of the floor protector, D was measured from each side of fuel-loading opening, E was calculated from the flue's surface to the rear wall.
2. The flue was installed onto the flue spigot, extended centrally and vertically without bend before and after penetration of the ceiling plane.
3. Drawings shown above are not to scale.