

ESCEA DL850; INSET FASCIA in STONE

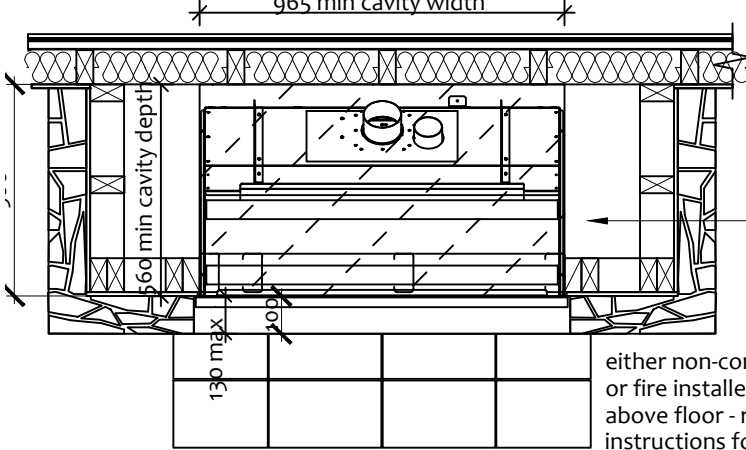

NOTE:
WALL LINING MUST BE SQUARE, OTHERWISE FASCIA WON'T FIT CORRECTLY

either non-combustible hearth or fire installed 100mm min above floor - refer written instructions for further detail

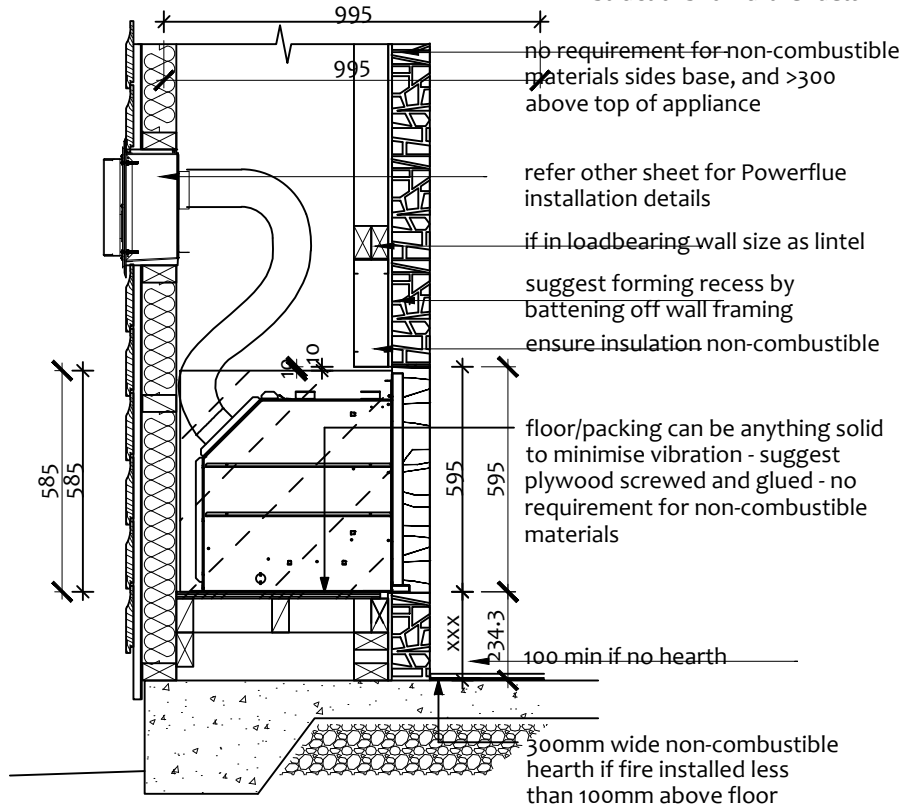

2 CROSS SECTION
Scale: 1:20

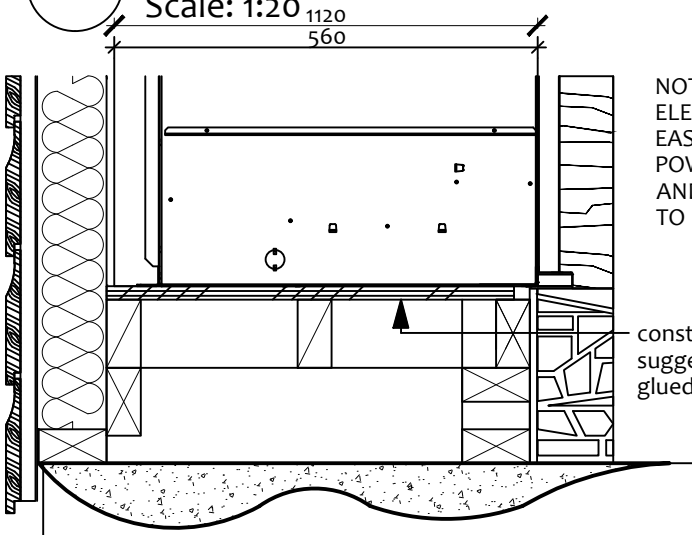

3 FLOOR DETAIL
Scale: 1:10

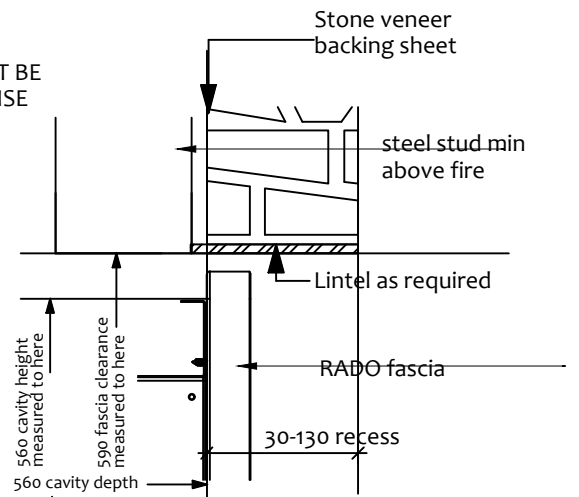

4 RECESSED HEAD
Scale: 1:5

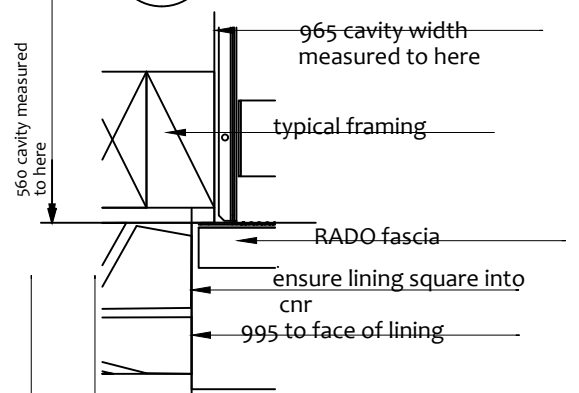

5 RECESSED JAMB
Scale: 1:5

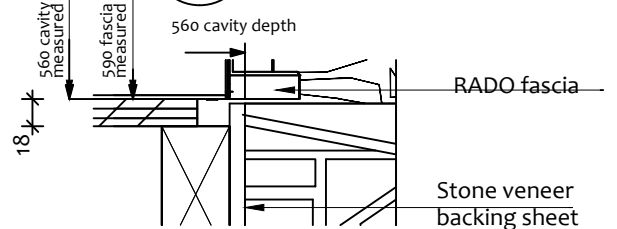

6 RECESSED BASE
Scale: 1:5

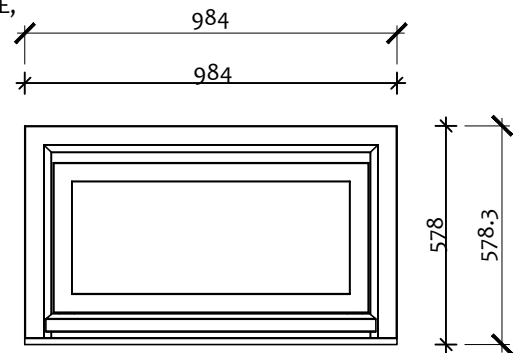

4 FASCIA DIMENSIONS
Scale: 1:20

NOTE:
ELECTRICIAN TO PROVIDE EASILY ACCESSIBLE ISOLATING POWER SWITCH TO APPLIANCE, AND NETWORK CABLE BACK TO ROUTER