



Suitable for outdoors only.
Wood burning barbecue and outdoor fire.
For further information or specifications, visit the technical section of our website www.escea.com to view the latest product Installation Manual.

Appliance Information

Specifications

Appliance Dimensions(mm) 996W x 758H x 548D
Appliance Weight 90.3kg

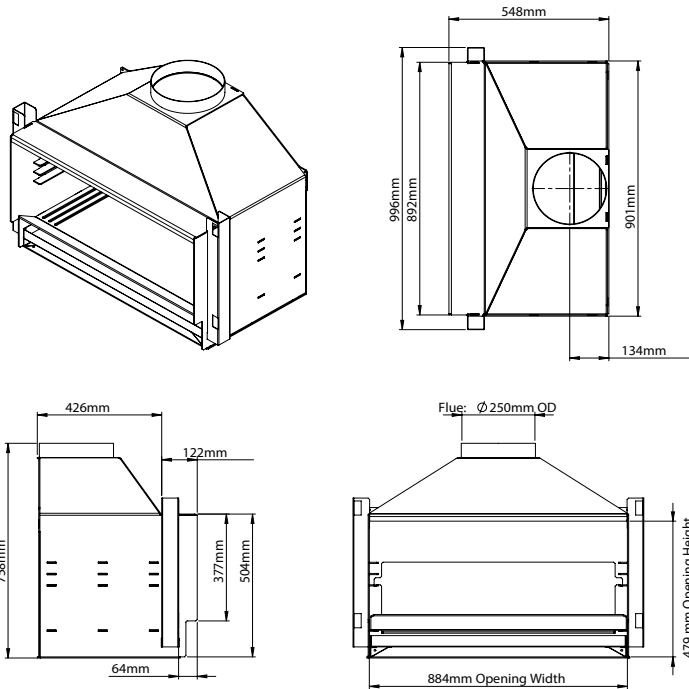

Concrete or Concrete Block Structure	
Minimum Internal Cavity Dimensions (mm):	1077W x 835D
Timber or Combustible Structure	
Minimum AAC Heat Cell Dimensions (mm):	1200W x 950H x 735D
Minimum Cavity Dimensions (mm):	1270W x 1550H x 770D

NOTE: For Concrete or Concrete Block Structure Height dimension depending on the installation method, please see the Installation Manual for details.

Cavity Construction

Minimum Requirements of Concrete | Concrete Block Structure

This appliance is designed for outdoor use ONLY.

The firebox and the flue system can be installed into a remote, free-standing, fully non-combustible fireplace construction on all surfaces surrounding the fireplace and flue. Example materials that can be used include: solid concrete, concrete/masonry blocks, bricks, or Hebel blocks/panels. **Do not use timber framing.**

For installations with a fascia, the position of the firebox must be located so that the appliance base is flush with the front face of the concrete structure. This is to allow the fascia to engage into the fascia brackets. Use the provided holes in the base to fix the firebox firmly down.

Depending on material choice, some heat may be conducted through the surrounding cavity and consequently no combustible materials should come into contact with these hot surfaces. This is completely dependant on the chosen material and design of installation. The user should satisfy themselves that the installation is fit for purpose and complies with all local and national codes.

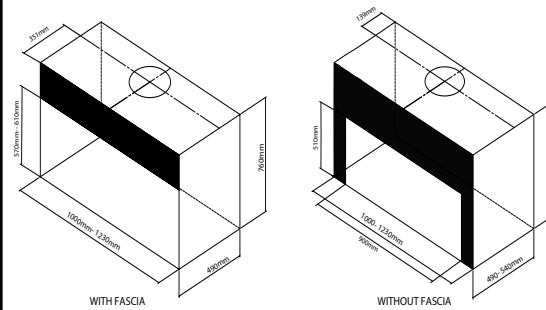

Corner installation

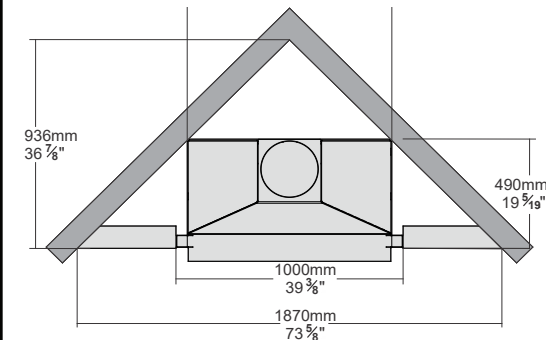

Minimum Requirements of the Timber | Combustible Structure

This appliance is designed for outdoor use ONLY.

It can also be installed within a free-standing timber/combustible cavity. The cavity structure must be free-standing and must not be connected to the envelope of a building. However, the cavity can penetrate through a combustible roof structure. The roof structure may be attached to a building.

For this scenario, the appliance must be enclosed within an Autoclaved Aerated Concrete (AAC) heat cell with a minimum thickness of 75mm thick panels having a thermal resistance/ R-value of no less than 0.59m² K/W. Additionally, the appliance must be installed with the EW Heat Cell Dropbox.

This scenario must be supplied with the triple skinned EW5000 Timber Cavity Flue Kit. The appliance must be frameless for this install scenario as the optional fascia is not compatible with this installation type.

Any cladding over the front of the structure (not including the chimney chase structure) must consist of a heat resistant material. Cladding over any other surface of the structure can consist of a combustible material (eg. plywood).

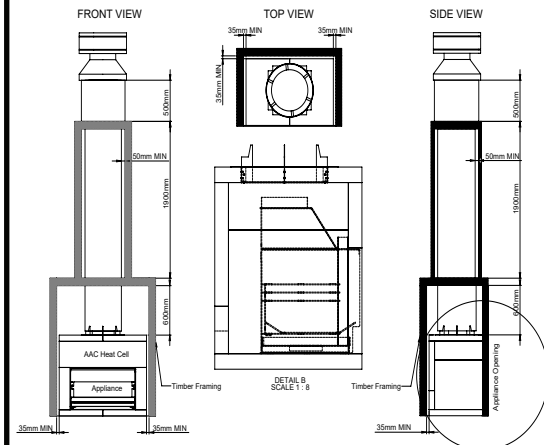

Flue Information

Flue Specifications for the Concrete | Concrete Block Structure

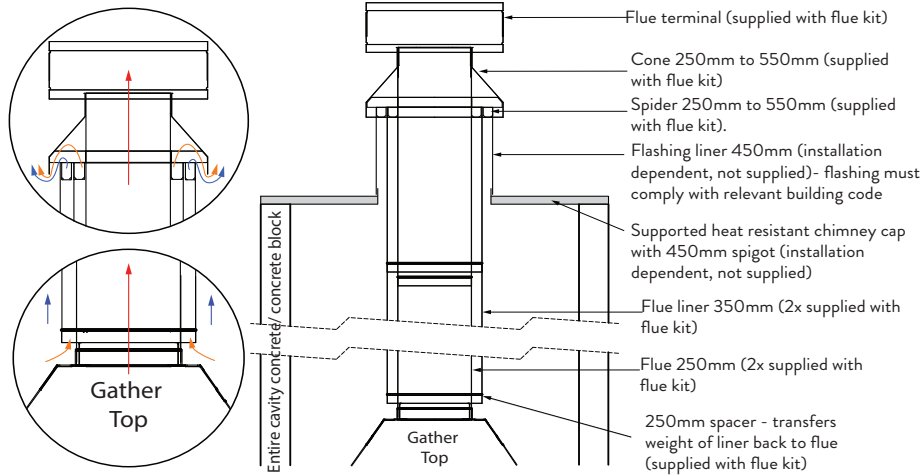

Flue Specifications for the Timber | Combustible Structure

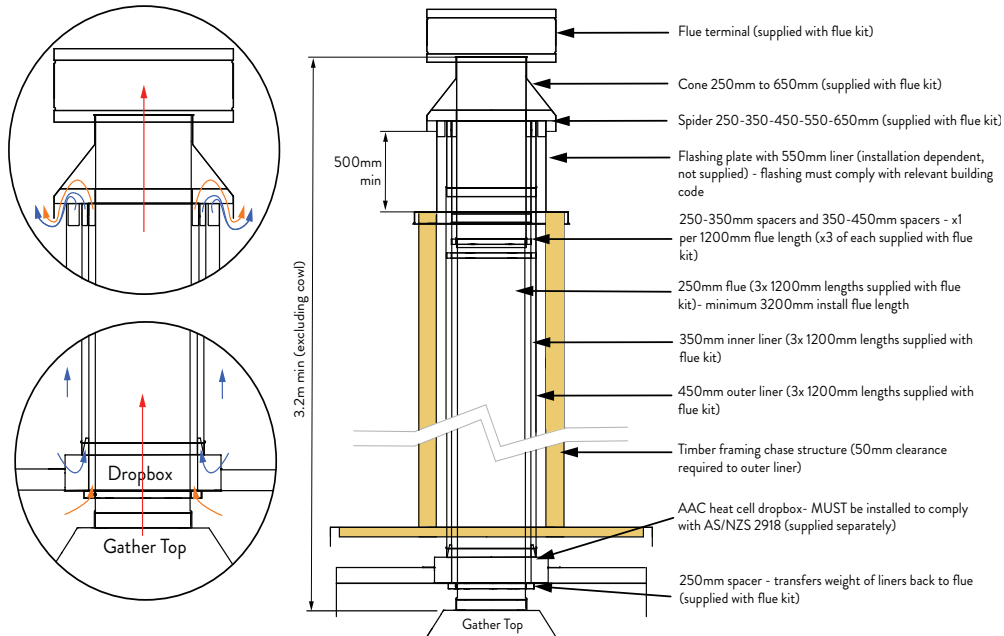

NOTE: The appliance & flue system shall be installed in accordance with AS/NZS 2918 and these specifications.

NOTE: The flashing requirements must comply with the Installation Manual relevant section D3 on page 12 or E4 on page 21, depending on the installation method of choice.

Venting & Sealing Requirements

The venting and sealing requirements must comply with the Installation Manual relevant section D1 and D2 on page 11 or section E2 and E3 on page 16, depending on the installation method of choice.

Clearances

External Clearances to Combustible Surfaces

The cavity structure must comply with the minimum requirements as stated on the previous page depending on the installation method of choice.

